

Catalogue number: **TS100-250 Range**

Thermal Magnetic and Electronic MCCB: 3,4 Pole 32A ~ 250A



Thermal Magnetic and Electronic MCCB Range

- Higher short circuit breaking capacity
- Fixed Dimensions
- Available in 3 or 4 Pole Range
- Optional Auxiliaries Available
- Shunt/Undervoltage release auxiliaries available.
- Auxiliary/Alarm/Fault Alarm auxiliary Switches available.

Generic photo only (actual product may change depending on configuration)

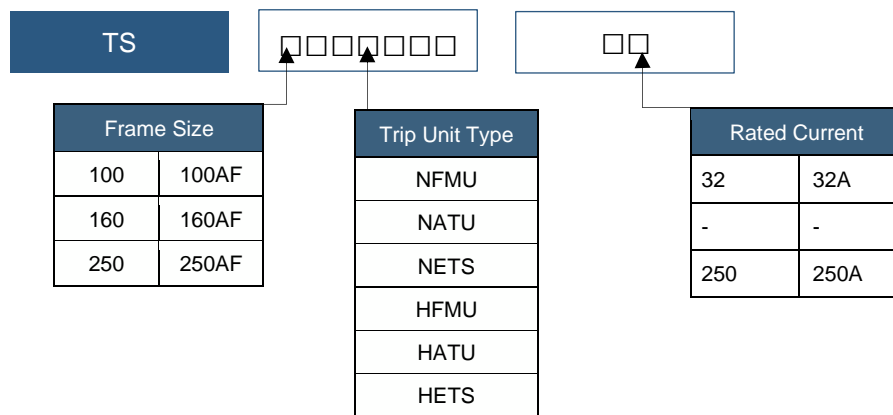

Trip Unit Types

MCCB Trip Unit Type	
NFMU	Normal Adjustable Thermal, Fixed Magnetic, 50kA
NATU	Normal Adjustable Thermal, Adjustable Magnetic, 50kA
NETS	Normal Electronic LSI, 50kA
HFMU	High Adjustable Thermal, Fixed Magnetic, 65kA
HATU	High Adjustable Thermal, Adjustable Magnetic, 65kA
HETS	High Electronic LSI, 65kA

***High, Normal* signifies the value of the short-circuit breaking capacity (Icu: kA rating)
 High- high short circuit breaking capacity.
 Normal- normal short circuit breaking capacity.

TS100 FMU, TS100 FMU

-Adjustable Thermal, Fixed Magnetic Trip Unit

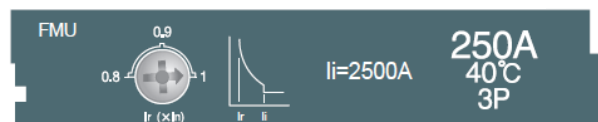

TS160 ATU, TS250 ATU

-Adjustable Thermal, Fixed Magnetic Trip Unit

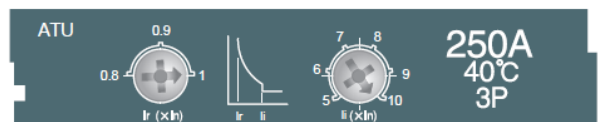

TS100 ETS, TS160 ETS, TS250 ETS,

-Electronic Trip Unit

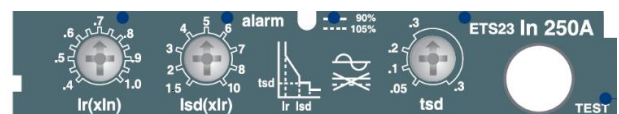

Specifications				MCCB Unit							
				TS100		TS160		TS250			
Frame Size	AF			100		160		250			
Rated Current	A			16-100		64-160		100-250			
No. of poles				3,4		3,4		3,4			
Rated operational voltage, Ue	AC	V		690		690		690			
	DC	V		500		500		500			
Rated impulse withstand voltage, Uimp		kV		8		8		8			
Rated Insulation Voltage. Ui		A		1000		1000		1000			
Rated Ultimate short-circuit breaking capacity, Icu	AC	220/240V	[kA]	N	H	N	H	N	H		
		380/415V	[kA]	100	120	100	120	100	120		
		440/460V	[kA]	50	85	50	85	50	85		
		480/500V	[kA]	50	70	50	70	50	70		
		525V	[kA]	42	65	42	65	42	65		
		660/690V	[kA]	22	35	22	35	22	35		
	DC	250V	kA]	10	10	10	10	10	10		
		500V(2P series)	[kA]	50	85	50	85	50	85		
	Rated service breaking Capacity Ics	AC	220/240V	[%Icu]	100%	100%	100%	100%	100%	100%	
			660/690V	[kA]	5	5	5	5	5	5	
DC		[%Icu]	100%	100%	100%	100%	100%	100%			
Rated short-circuit making capacity Icm	AC	220/240V	[kA]	220	264	220	264	220	264		
		380/415V	[kA]	105	187	105	187	105	187		
		440/460V	[kA]	105	154	105	154	105	154		
		480/500V	[kA]	88	143	88	143	88	143		
		525V	[kA]	46	74	46	74	46	74		
		660/690V	[kA]	17	17	17	17	17	17		
Trip Unit (release) Available				FTU, FMU, MTU, ETS		FTU, FMU, ATU, MTU, ETS		FTU, FMU, ATU, MTU, ETS			
Mechanical life		Operations		25000		25000		25000			
Electrical life @415 VAC	AC	Operations		10000		10000		10000			
Reference standard				IEC60947-2		IEC60947-2		IEC60947-2			

Catalogue number: **TS100-250 Range**

Thermal Magnetic and Electronic MCCB: 3,4 Pole 32A ~ 250A



TS100/160 FMU Setting Configuration

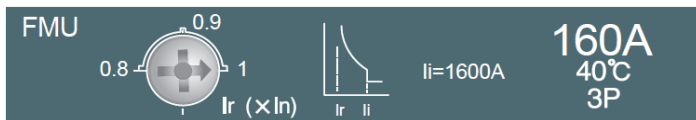
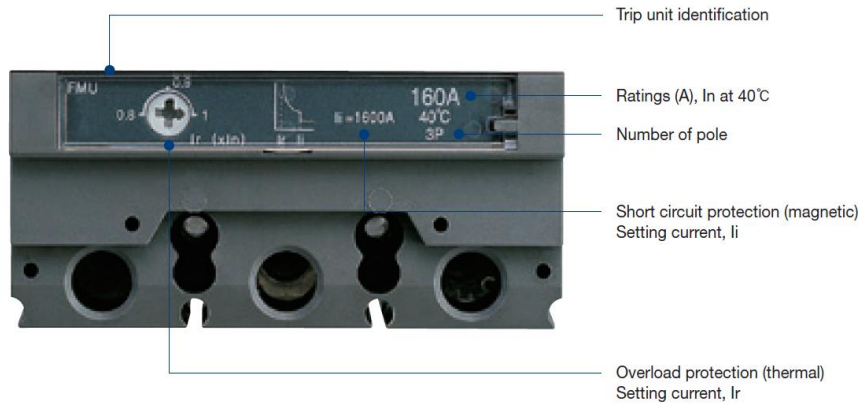
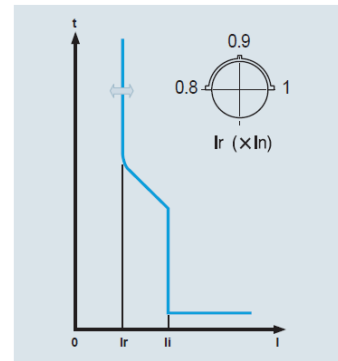

Figure 1 Adjustable Thermal & Fixed Magnetic trip unit



Thermal Overload Protection, Ir (xIn)

Trip Unit Type	Setting Current, Ir	Trip Unit Rating, In(A)							
		40	50	63	80	100	125	160	
TS100FMU	0.8xIn	32	40	50	64	80	-	-	
	0.9xIn	36	45	57	72	90	-	-	
	1.0xIn	40	50	63	80	100	-	-	
TS160FMU	0.8xIn	-	-	-	-	80	100	128	
	0.9xIn	-	-	-	-	90	113	144	
	1.0xIn	-	-	-	-	100	125	160	

Magnetic-short Circuit Protection, Ii

Setting Current, Ir	Setting Current Ii	Trip Unit Rating, In(A)							
		40	50	63	80	100	125	160	
0.8xIn	Fixed	Inx10	400	500	630	800	1000	-	-
0.9xIn	Fixed	Inx10	400	500	630	800	1000	-	-
1.0xIn	Fixed	Inx10	400	500	630	800	1000	-	-
0.8xIn	Fixed	Inx10	-	-	-	-	1000	1250	1600
0.9xIn	Fixed	Inx10	-	-	-	-	1000	1250	1600
1.0xIn	Fixed	Inx10	-	-	-	-	1000	1250	1600



TS100 FMU Characteristic Curve

- TS100NFMU40
- TS100NFMU63
- TS100NFMU80
- TS100NFMU100
- TS100NFMU100/4
- TS100HFMU40
- TS100HFMU63
- TS100HFMU80
- TS100HFMU100
- TS100HFMU100/4 TS1

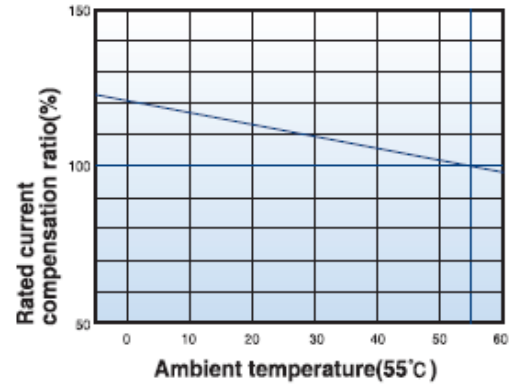
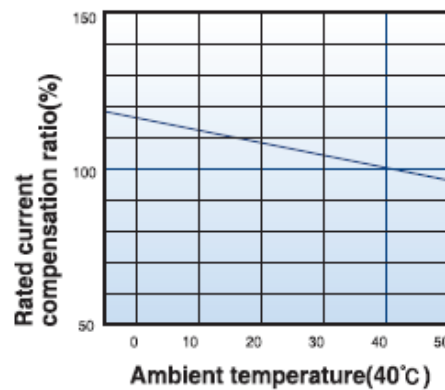
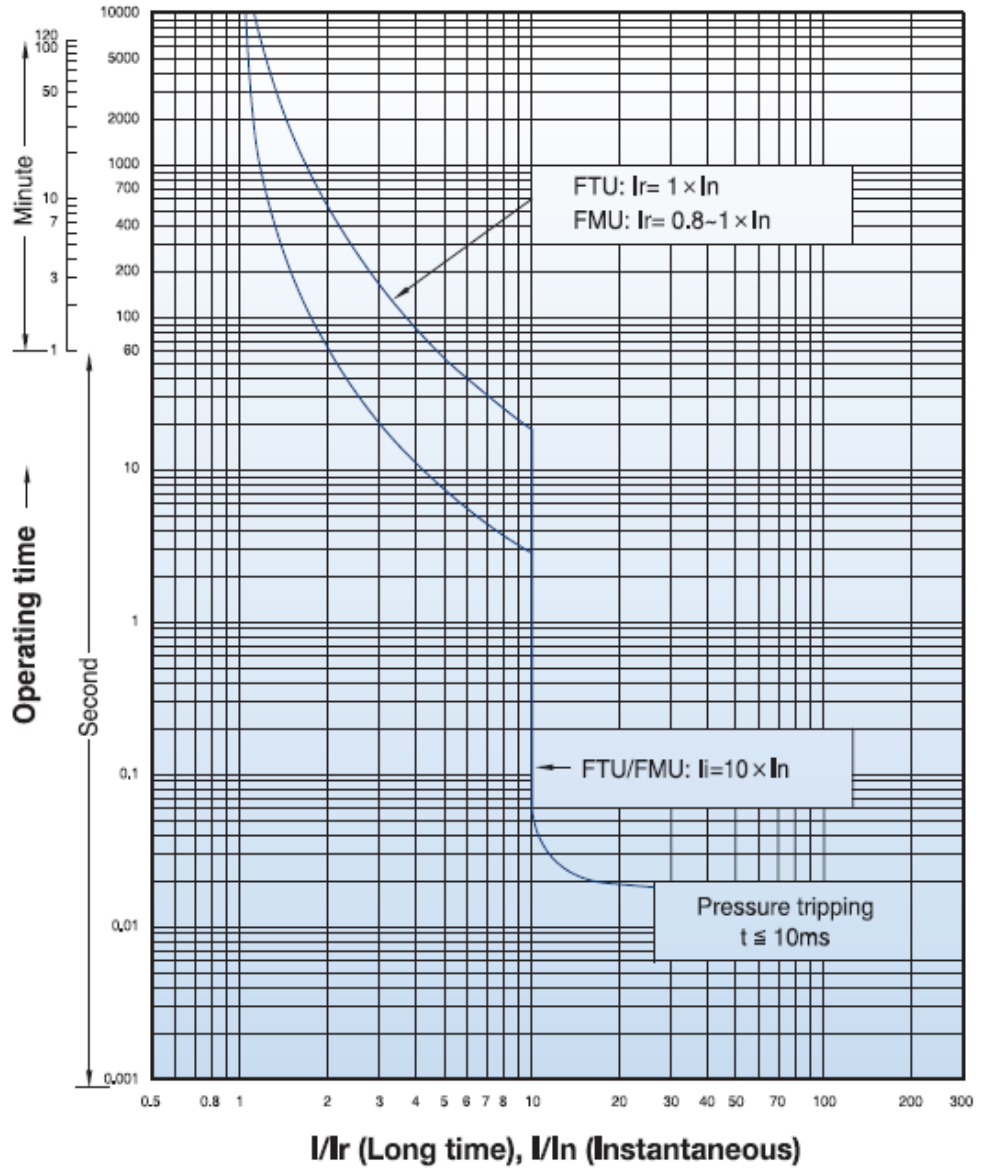

TS160 FMU Characteristic Curve

- TS160NFMU100
- TS160NFMU125
- TS160NFMU160
- TS160NFMU100/4
- TS160HFMU100
- TS160HFMU125
- TS160HFMU160
- TS160HFMU100/4
- TS160HFMU160/4

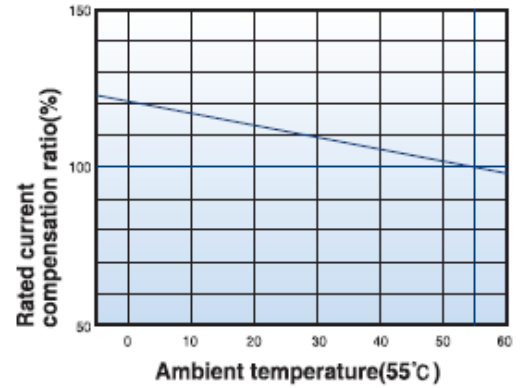
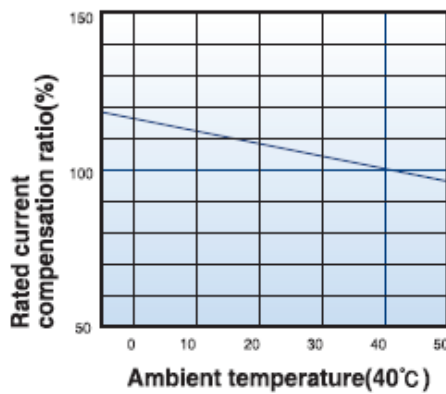
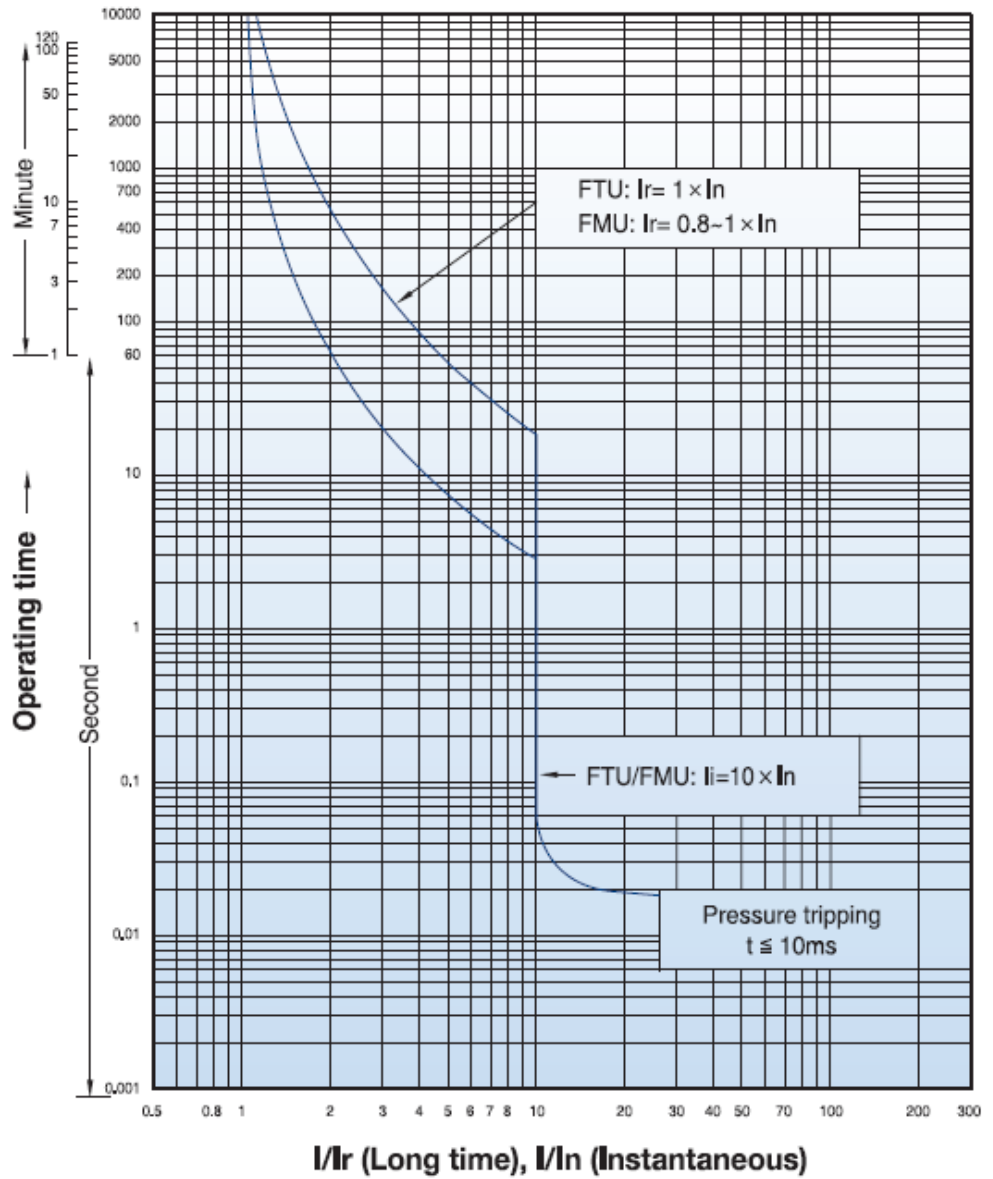

TS100/160 ATU Setting Configuration

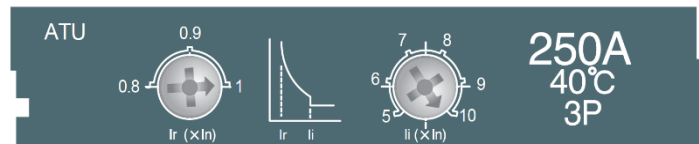
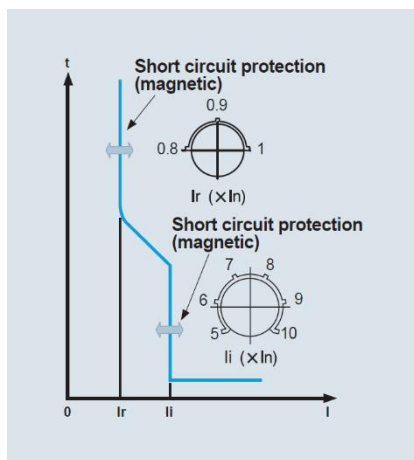
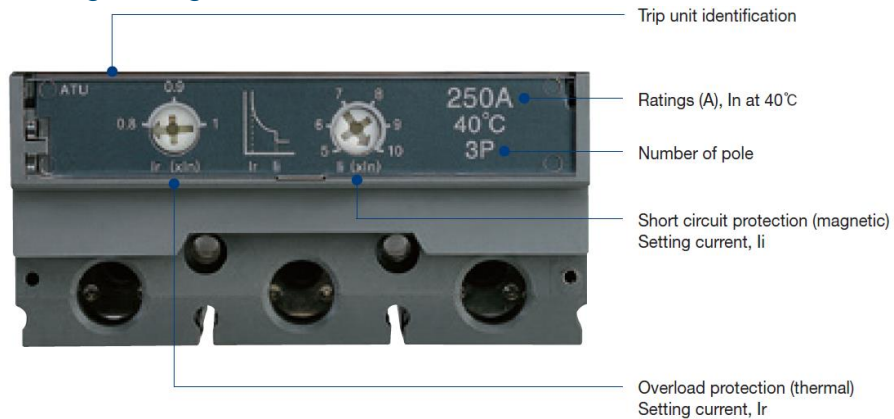

Figure 2 Adjustable Thermal and Adjustable Magnetic

Thermal Overload Protection, $I_r (\times I_n)$

Trip Unit Type	Setting Current, I_r	Trip Unit Rating, $I_n(A)$			
		125	160	200	250
TS250ATU	0.8x I_n	100	128	160	200
	0.9x I_n	113	144	180	225
	1.0x I_n	125	160	200	250

Magnetic Short Circuit Protection, $I_i (\times I_n)$

Setting Current, I_r	Setting Current I_i	Trip Unit Rating, $I_n(A)$				
		125	160	200	250	
0.8x I_n	Adjustable	$I_n \times 5$	625	800	1000	1250
		$I_n \times 6$	750	960	1200	1500
		$I_n \times 7$	875	1120	1400	1750
		$I_n \times 8$	1000	1280	1600	2000
		$I_n \times 9$	1125	1440	1800	2250
		$I_n \times 10$	1250	1600	2000	2500
0.9x I_n	Adjustable	$I_n \times 5$	625	800	1000	1250
		$I_n \times 6$	750	960	1200	1500
		$I_n \times 7$	875	1120	1400	1750
		$I_n \times 8$	1000	1280	1600	2000
		$I_n \times 9$	1125	1440	1800	2250
		$I_n \times 10$	1250	1600	2000	2500
1.0x I_n	Adjustable	$I_n \times 5$	625	800	1000	1250
		$I_n \times 6$	750	960	1200	1500
		$I_n \times 7$	875	1120	1400	1750
		$I_n \times 8$	1000	1280	1600	2000
		$I_n \times 9$	1125	1440	1800	2250
		$I_n \times 10$	1250	1600	2000	2500

TS250 ATU Characteristic Curve

- TS250NATU125
- TS250NATU160
- TS250NATU200
- TS250NATU
- TS250NATU100/4
- TS250NATU250/4
- TS250HATU125
- TS250HATU160
- TS250HATU200
- TS250HATU250
- TS250HATU100/4
- TS250HATU250/4

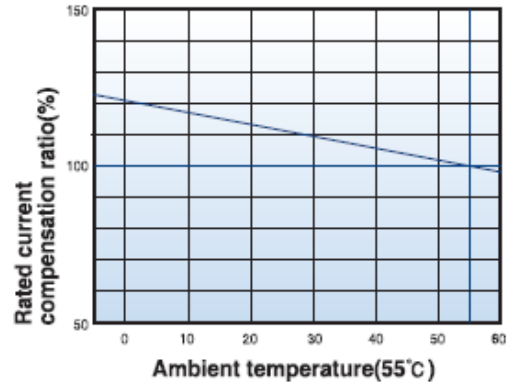
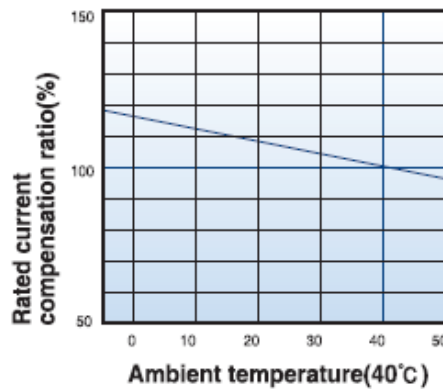
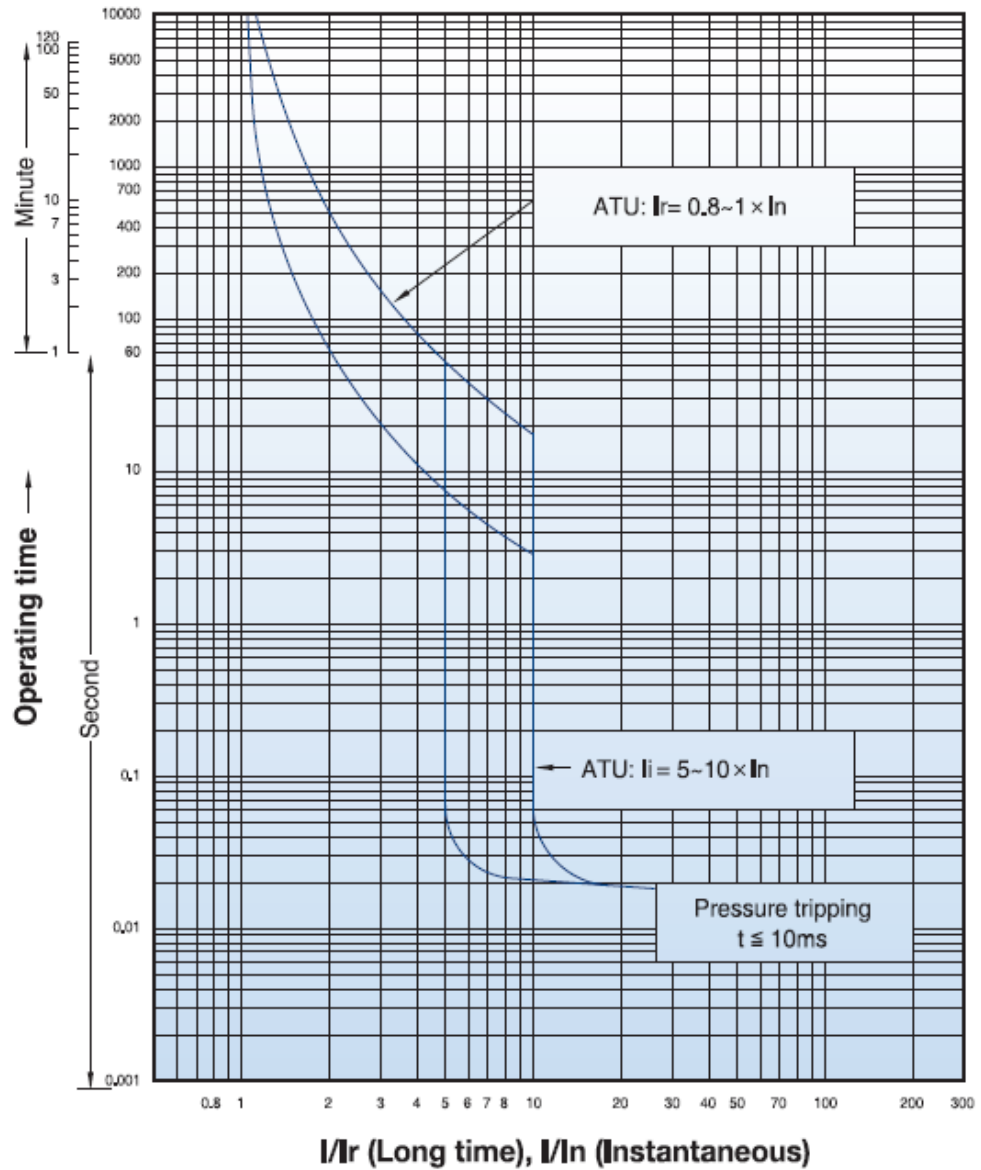

TS100/160/250 ETS Setting Configuration

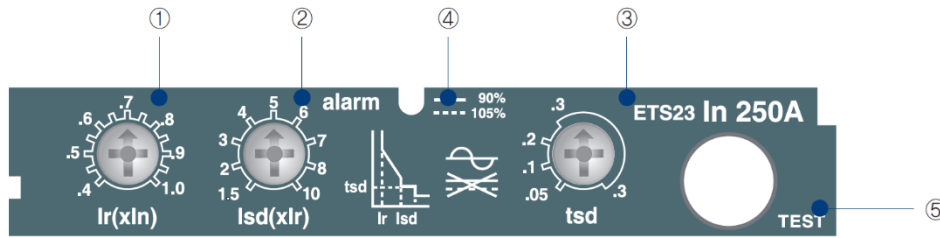

1. Adjustable rated current setting (I_r)
2. Adjustable short time delay current setting (I_{sd})
3. Adjustable time delay setting (t_{sd})
4. Alarm LED 90% I_r : ON,
105% I_r or more: ON-OFF
5. Test connector

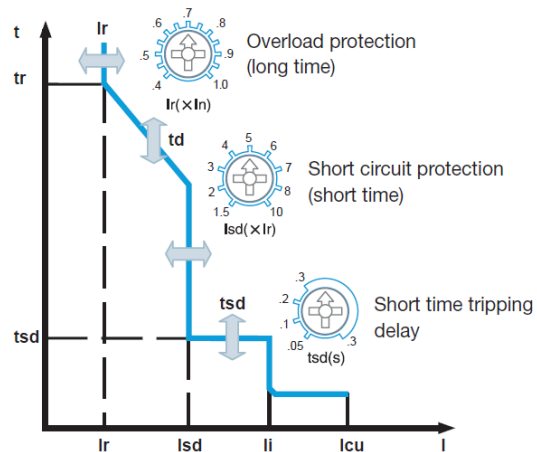

Overload Protection (Long Time), I_r

Circuit Breakers	TS100		TS160	TS250
Trip Unit In(A)	40	80	160	250
Setting Value	Overload Protection setting current, $I_r = \text{Setting Value}(0.4-1) \times I_n$			
0.4	16	32	64	100
0.45	18	36	72	113
0.5	20	40	80	125
0.55	22	44	88	138
0.6	24	48	96	150
0.65	26	52	104	163
0.7	28	56	112	175
0.75	30	60	120	188
0.8	32	64	128	200
0.85	34	68	136	213
0.9	36	72	144	225
0.95	38	76	152	238
1	40	80	160	250

Long Time tripping delay, t_d (sec)

Tripping Time (s)	Fixed at 6 x I_r
	Tolerance $\pm 20\%$

Short Time tripping setting, t_{sd} (ms)

Time delay (t_{ds})	setting time (ms)	50	100	200	300	4 Settings
	operation Time	$30 < t \leq 70$	$70 < t \leq 140$	$140 < t \leq 240$	$240 < t \leq 350$	

Short circuit protection (instantaneous), I_i (A)

Tripping threshold(A), I_i	Fixed at 11 x I_n
--	---------------------

Short-circuit Protection (short time), $I_{sd}(xI_r)$

Circuit Breakers	TS100	TS160	TS250	
Trip Unit $I_n(A)$	40	80	160	250
Setting Value	Short Time pick up current Setting, $I_{sd} = \text{Setting Value}(1.5-1.0) \times I_r$			
0.4	24	48	96	150
0.45	27	54	108	169
0.5	30	60	120	188
0.55	33	66	132	206
0.6	36	72	144	225
0.65	39	78	156	244
0.7	42	84	168	263
0.75	45	90	180	281
0.8	48	96	192	300
0.85	51	102	204	319
0.9	54	108	216	338
0.95	57	114	228	356
1	60	120	240	375
0.4	32	64	128	200
0.45	36	72	144	225
0.5	40	80	160	250
0.55	44	88	176	275
0.6	48	96	192	300
0.65	52	104	208	325
0.7	56	112	224	350
0.75	60	120	240	375
0.8	64	128	256	400
0.85	68	136	272	425
0.9	72	144	288	450
0.95	76	152	304	475
1	80	160	320	500

Circuit Breakers	TS100	TS160	TS250	
Trip Unit $I_n(A)$	40	80	160	250
Setting Value	Short Time pick up current Setting, $I_{sd} = \text{Setting Value}(1.5-1.0) \times I_r$			
0.4	48	96	192	300
0.45	54	108	216	338
0.5	60	120	240	375
0.55	66	132	264	413
0.6	72	144	288	450
0.65	78	156	312	488
0.7	84	168	336	525
0.75	90	180	360	563
0.8	96	192	384	600
0.85	102	204	408	638
0.9	108	216	432	675
0.95	114	228	456	713
1	120	240	480	750
0.4	64	128	256	400
0.45	72	144	288	450
0.5	80	160	320	500
0.55	88	176	352	550
0.6	96	192	384	600
0.65	104	208	416	650
0.7	112	224	448	700
0.75	120	240	480	750
0.8	128	256	512	800
0.85	136	272	544	850
0.9	144	288	576	900
0.95	152	304	608	950
1	160	320	640	1000

Catalogue number: **TS100-250 Range**

Thermal Magnetic and Electronic MCCB: 3,4 Pole 32A ~ 250A



Circuit Breakers		TS100		TS160	TS250	
Trip Unit In(A)		40	80	160	250	
Setting Value		Short Time pick up current Setting, I _{sd} = Setting Value(1.5-1.0)xI _r				
0.4	5	80	160	320	500	
0.45		90	180	360	563	
0.5		100	200	400	625	
0.55		110	220	440	688	
0.6		120	240	480	750	
0.65		130	260	520	813	
0.7		140	280	560	875	
0.75		150	300	600	938	
0.8		160	320	640	1000	
0.85		170	340	680	1063	
0.9		180	360	720	1125	
0.95		190	380	760	1188	
1		200	400	800	1250	
0.4		6	96	192	384	600
0.45			108	216	432	675
0.5	120		240	480	750	
0.55	132		264	528	825	
0.6	144		288	576	900	
0.65	156		312	624	975	
0.7	168		336	672	1050	
0.75	180		360	720	1125	
0.8	192		384	768	1200	
0.85	204		408	816	1275	
0.9	216		432	864	1350	
0.95	228		456	912	1425	
1	240		480	960	1500	
0.4	7		112	224	448	700
0.45			126	252	504	788
0.5		140	280	560	875	
0.55		154	308	616	963	
0.6		168	336	672	1050	
0.65		182	364	728	1138	
0.7		196	392	784	1225	
0.75		210	420	840	1313	
0.8		224	448	896	1400	
0.85		238	476	952	1488	
0.9		252	504	1008	1575	
0.95		266	532	1064	1663	
1		280	560	1120	1750	

Circuit Breakers		TS100		TS160	TS250	
Trip Unit In(A)		40	80	160	250	
Setting Value		Short Time pick up current Setting, I _{sd} = Setting Value(1.5-1.0)xI _r				
0.4	8	128	256	512	800	
0.45		144	288	576	900	
0.5		160	320	640	1000	
0.55		176	352	704	1100	
0.6		192	384	768	1200	
0.65		208	416	832	1300	
0.7		224	448	896	1400	
0.75		240	480	960	1500	
0.8		256	512	1024	1600	
0.85		272	544	1088	1700	
0.9		288	576	1152	1800	
0.95		304	608	1216	1900	
1		320	640	1280	2000	
0.4		10	160	320	640	1000
0.45			180	360	720	1125
0.5	200		400	800	1250	
0.55	220		440	880	1375	
0.6	240		480	960	1500	
0.65	260		520	1040	1625	
0.7	280		560	1120	1750	
0.75	300		600	1200	1875	
0.8	320		640	1280	2000	
0.85	340		680	1360	2125	
0.9	360		720	1440	2250	
0.95	380		760	1520	2375	
1	400		800	1600	2500	



TS100-250 ETS Characteristic Curve

- TS100NETS40
- TS100NETS80
- TS100HETS40
- TS100HETS80
- TS160NETS160
- TS160HETS160
- TS250NETS250
- TS250HETS250

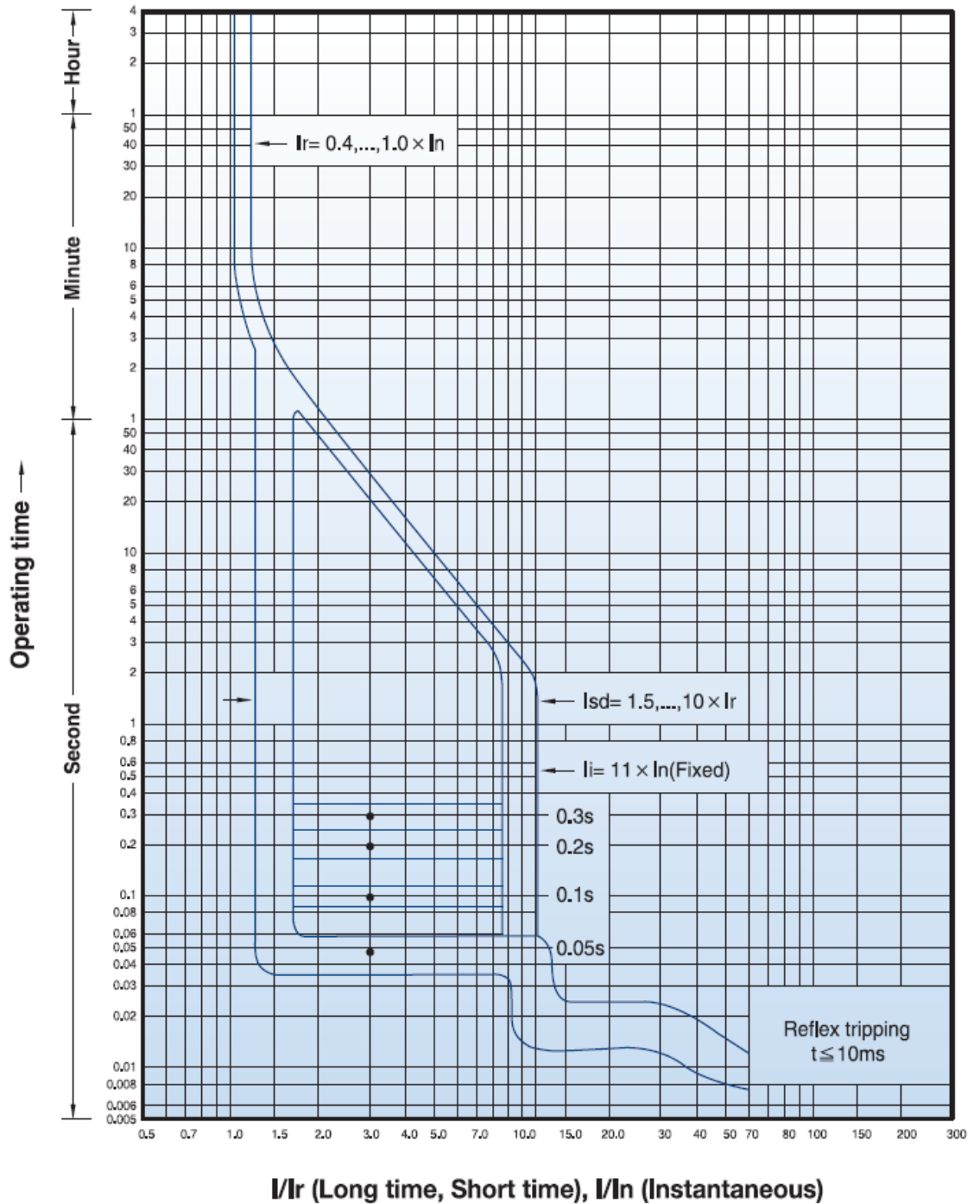

Catalogue number: **TS100-250 Range**

Thermal Magnetic and Electronic MCCB: 3,4 Pole 32A ~ 250A



TS100-250 Overall Dimensions
 TS100, TS160, TS250

[mm]

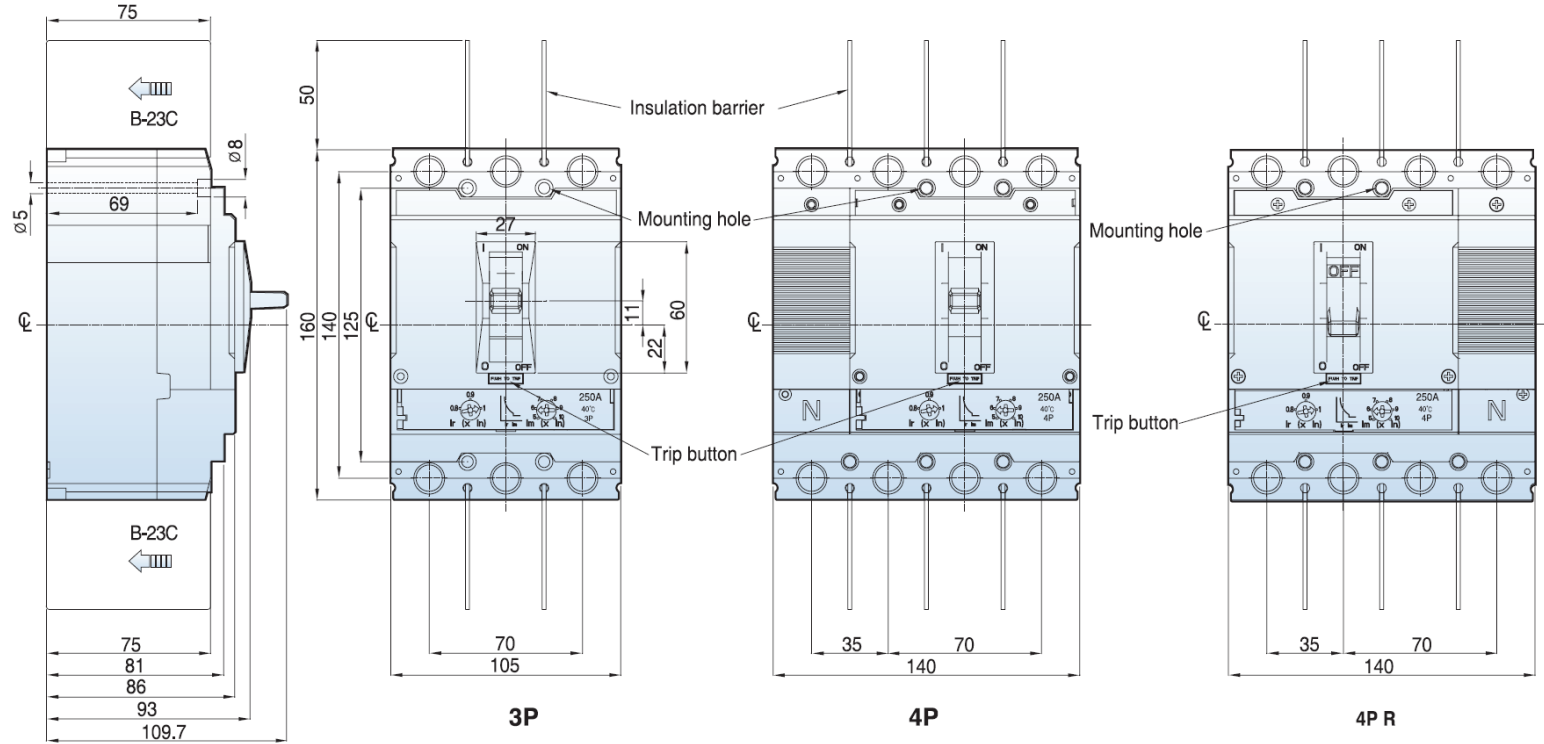

Terminal section

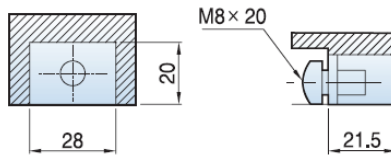

Conductor

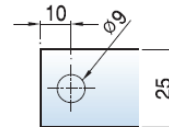

Panel drilling

Front panel cutting

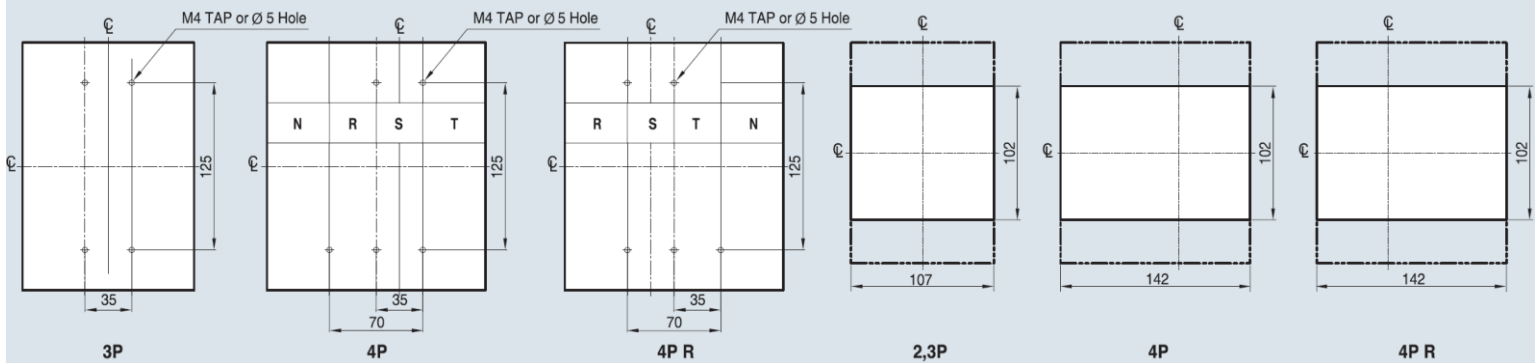

N.A.W. Controls Pty. Ltd.
 Telephone: (03) 9464 6555
www.nawcontrols.com.au

LS MCCB TS 250, 160 & 100 range
 May 2020