

Catalogue number: **TS400/630/800 Range**

Thermal Magnetic and Electronic MCCB: 2,3,4 Pole 160A ~ 800A



Thermal Magnetic And Electronic MCCB Range

- Higher short circuit breaking capacity
- Fixed Dimensions
- Available in 2,3 or 4 Pole Range
- Optional Auxiliaries Available
- Shunt/Undervoltage release auxiliaries available.
- Auxiliary/Alarm/Fault Alarm auxiliary Switches available.

Generic photo only (actual product may change depending on configuration)

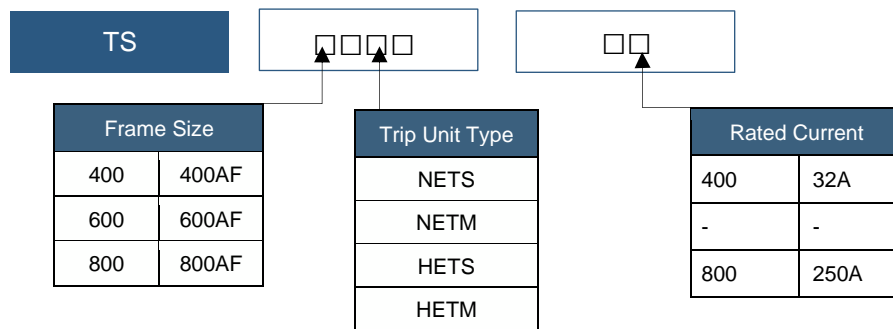

Trip Unit Types

MCCB Trip Unit Type	
NETS	Normal Electronic Trip unit's standard
NETM	Normal Electronic Trip unit's multifunction
HETS	High Electronic Trip unit's standard
HETM	High Electronic Trip units' multifunction

\*\*\*High, Normal\* signifies the value of the short-circuit breaking capacity (Icu: kA rating)  
 High- high short circuit breaking capacity.  
 Normal- normal short circuit breaking capacity.

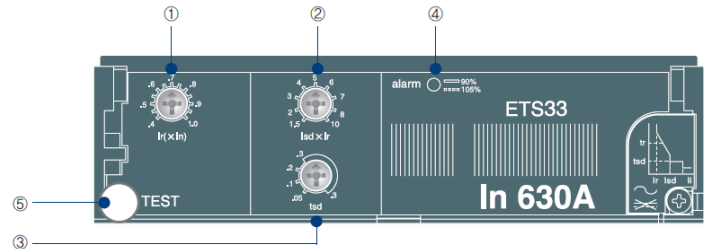

- 1 Adjustable rated current setting (Ir)
- 2 Adjustable short time delay current setting (Isd)
- 3 Adjustable time delay setting (tsd)
- 4 Alarm LED 90% Ir: ON, 105% Ir or more: ON-OFF
- 5 Test connector

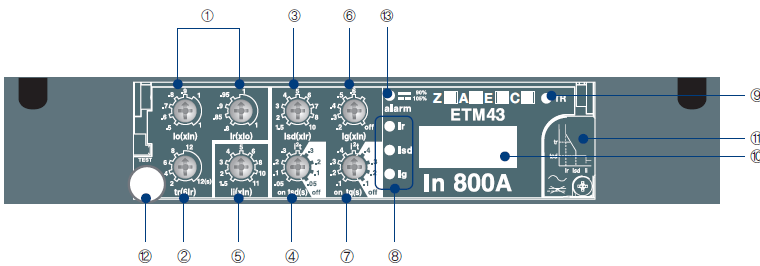

- 1 Adjustable rated current setting (Ir)
- 2 Adjustable long time setting (tr)
- 3 Adjustable short time current setting (Isd)
- 4 Adjustable time delay setting (tsd)
- 5 Adjustable instantaneous current setting (Ii)
- 6 Adjustable earth fault current setting (Ig)
- 7 Adjustable earth fault delay setting (tg)
- 8 Indication LED
- 9 TR (trip reason) button
- 10 Display LCD (Ammeter)
- 11 Auxiliary power
- 12 Test connector
- 13 Alarm LED



Specifications			MCCB Type					
			TS400		TS630		TS800	
Frame Size	AF		400		630		800	
Rated Current	A		300,400		500,630		500,630	
No. of poles			2,3,4		2,3,4		2,3,4	
Rated operational voltage, Ue	AC	V	690		690		690	
	DC	V	500		500		500	
Rated impulse withstand voltage, Uimp		kV	8		8		8	
Rated Insulation Voltage. Ui		A	1000		1000		1000	
Rated Ultimate short-circuit breaking capacity, Icu	AC	220/240V [kA]	N	H	N	H	N	H
		380/415V [kA]	100	120	100	120	100	120
		440/460V [kA]	65	85	65	85	65	100
		480/500V [kA]	65	85	65	85	65	100
		525V [kA]	42	65	42	65	42	85
		660/690V [kA]	22	35	22	35	22	35
	DC	250V [kA]	10	20	10	20	10	20
		500V(2P series) [kA]	50	85	50	85	50	85
Rated service breaking Capacity Ics	AC	220/240V [%Icu]	100%	100%	100%	100%	100%	100%
		660/690V [kA]	10	12	10	12	10	20
	DC	[%Icu]	100%	100%	100%	100%	100%	100%
Rated short-circuit making capacity Icm	AC	220/240V [kA]	220	264	220	264	220	264
		380/415V [kA]	143	187	143	187	143	220
		440/460V [kA]	143	187	143	187	143	220
		480/500V [kA]	88	143	88	143	88	187
		525V [kA]	46	74	46	74	46	74
		660/690V [kA]	17	40	17	40	17	40
Trip Unit (release) Available			ETS, ETM		ETS, ETM		ETS, ETM	
Mechanical life		Operations	20000		20000		10000	
Electrical life @415 VAC	AC	Operations	10000		6000		3000	
Reference standard			IEC60947-2		IEC60947-2		IEC60947-2	

**TS400/630/800 ETS, Standard Electronic MCCB Setting Configuration**

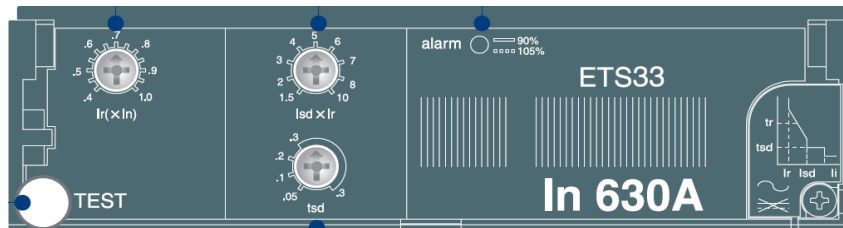
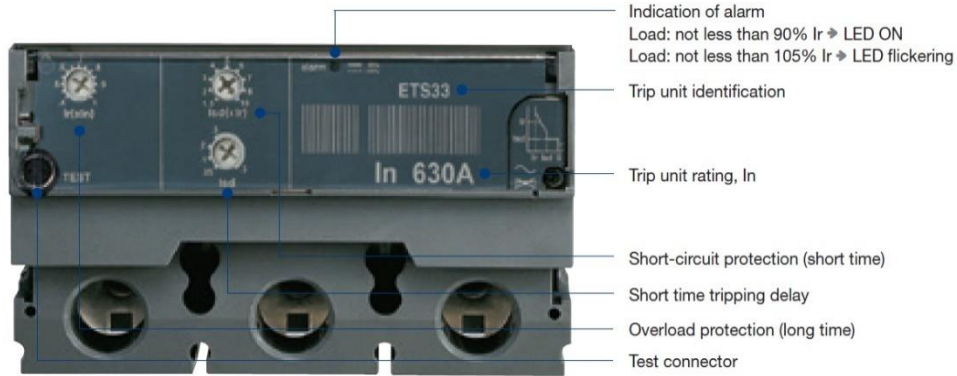

Figure 1 ETS33 Electronic Trip Unit

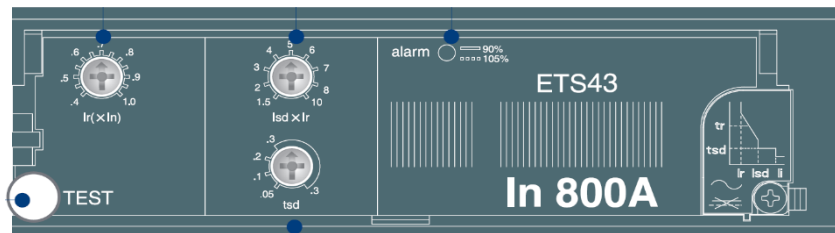
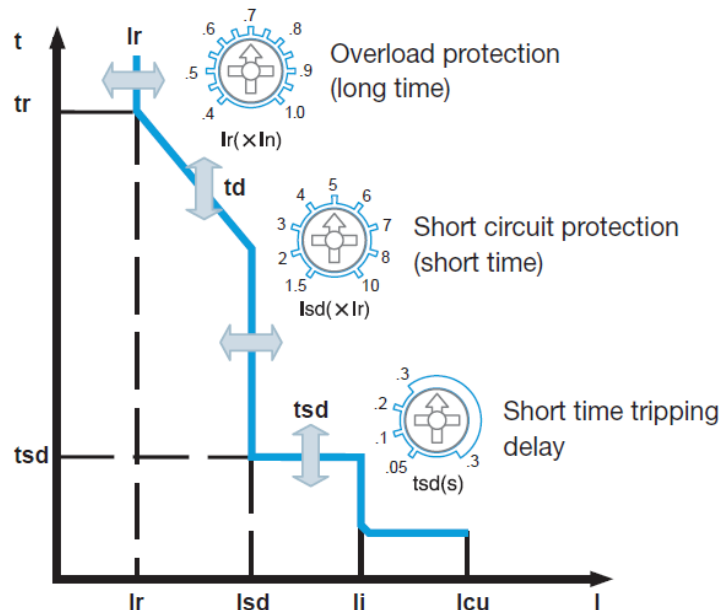

Figure 2 ETS43 Electronic Trip Unit



Overload Protection (Long Time), Ir

Circuit Breakers	TS400	TS630	TS800
Trip Unit In(A)	400	630	800
Setting Value	Overload Protection setting current, $I_r = \text{Setting Value}(0.4-1) \times I_n$		
0.4	160	252	320
0.45	180	284	360
0.5	200	315	400
0.55	220	347	440
0.6	240	378	480
0.65	260	410	520
0.7	280	441	560
0.75	300	473	600
0.8	320	504	640
0.85	340	536	680
0.9	360	567	720
0.95	380	599	760
1	400	630	800

Long Time tripping delay, td (sec)

Tripping Time (s)	Fixed at 6 x Ir Tolerance $\pm 20\%$
-------------------	---

Short Time tripping setting, tsd (ms)

Time delay (tds)	setting time (ms)	50	100	200	300	4 Settings
	operation time (ms)	30<t≤70	70<t≤140	140<t≤240	240<t≤350	

Short circuit protection (Instantaneous), Ii (A)

Tripping Threshold (A), Ii	Fixed at 11 x In
----------------------------	---------------------

Short-circuit Protection (short time), Isd(xI<sub>r</sub>)

Circuit Breakers		TS400	TS630	TS800
Trip Unit In(A)		400	630	800
Setting Value		Short Time pick up current Setting, Isd= Setting Value(1.5-1.0)xI <sub>r</sub>		
0.4	1.5	240	378	480
0.45		270	425	540
0.5		300	473	600
0.55		330	520	660
0.6		360	567	720
0.65		390	614	780
0.7		420	662	840
0.75		450	709	900
0.8		480	756	960
0.85		510	803	1020
0.9		540	851	1080
0.95		570	898	1140
1		600	945	1200
0.4		2	320	504
0.45	360		567	720
0.5	400		630	800
0.55	440		693	880
0.6	480		756	960
0.65	520		819	1040
0.7	560		882	1120
0.75	600		945	1200
0.8	640		1008	1280
0.85	680		1071	1360
0.9	720		1134	1440
0.95	760		1197	1520
1	800		1260	1600
0.4	3		480	756
0.45		540	851	1080
0.5		600	945	1200
0.55		660	1040	1320
0.6		720	1134	1440
0.65		780	1229	1560
0.7		840	1323	1680
0.75		900	1418	1800
0.8		960	1512	1920
0.85		1020	1607	2040
0.9		1080	1701	2160
0.95		1140	1796	2280
1		1200	1890	2400

Circuit Breakers		TS400	TS630	TS800
Trip Unit In(A)		400	630	800
Setting Value		Short Time pick up current Setting, Isd= Setting Value(1.5-1.0)xI <sub>r</sub>		
0.4	4	640	1008	1280
0.45		720	1134	1440
0.5		800	1260	1600
0.55		880	1386	1760
0.6		960	1512	1920
0.65		1040	1638	2080
0.7		1120	1764	2240
0.75		1200	1890	2400
0.8		1280	2016	2560
0.85		1360	2142	2720
0.9		1440	2268	2880
0.95		1520	2394	3040
1		1600	2520	3200
0.4		5	800	1260
0.45	900		1418	1800
0.5	1000		1575	2000
0.55	1100		1733	2200
0.6	1200		1890	2400
0.65	1300		2048	2600
0.7	1400		2205	2800
0.75	1500		2363	3000
0.8	1600		2520	3200
0.85	1700		2678	3400
0.9	1800		2835	3600
0.95	1900		2993	3800
1	2000		3150	4000
0.4	6		960	1512
0.45		1080	1701	2160
0.5		1200	1890	2400
0.55		1320	2079	2640
0.6		1440	2268	2880
0.65		1560	2457	3120
0.7		1680	2646	3360
0.75		1800	2835	3600
0.8		1920	3024	3840
0.85		2040	3213	4080
0.9		2160	3402	4320
0.95		2280	3591	4560
1		2400	3780	4800

Catalogue number: **TS400/630/800 Range**

Thermal Magnetic and Electronic MCCB: 2,3,4 Pole 160A ~ 800A



Circuit Breakers		TS400	TS630	TS800
Trip Unit In(A)		400	630	800
Setting Value		Short Time pick up current Setting, $I_{sd} = \text{Setting Value}(1.5-1.0) \times I_r$		
0.4	7	1120	1764	2240
0.45		1260	1985	2520
0.5		1400	2205	2800
0.55		1540	2426	3080
0.6		1680	2646	3360
0.65		1820	2867	3640
0.7		1960	3087	3920
0.75		2100	3308	4200
0.8		2240	3528	4480
0.85		2380	3749	4760
0.9		2520	3969	5040
0.95		2660	4190	5320
1		2800	4410	5600
0.4	8	1280	2016	2560
0.45		1440	2268	2880
0.5		1600	2520	3200
0.55		1760	2772	3520
0.6		1920	3024	3840
0.65		2080	3276	4160
0.7		2240	3528	4480
0.75		2400	3780	4800
0.8		2560	4032	5120
0.85		2720	4284	5440
0.9		2880	4536	5760
0.95		3040	4788	6080
1		3200	5040	6400
0.4	10	1600	2520	3200
0.45		1800	2835	3600
0.5		2000	3150	4000
0.55		2200	3465	4400
0.6		2400	3780	4800
0.65		2600	4095	5200
0.7		2800	4410	5600
0.75		3000	4725	6000
0.8		3200	5040	6400
0.85		3400	5355	6800
0.9		3600	5670	7200
0.95		3800	5985	7600
1		4000	6300	8000



N.A.W. Controls Pty. Ltd.  
 Telephone: (03) 9464 6555  
[www.nawcontrols.com.au](http://www.nawcontrols.com.au)

LS MCCB TS 400,630 & 800  
 Electronic range  
 May 2020

**TS400/630/800 ETS Characteristic Curve**

- TS400NETS400
- TS400NETS400/4
- TS630NETS630
- TS630NETS630/4
- TS400HETS400
- TS400HETS400/4
- TS630HETS630
- TS630HETS630/4
- TS800NETS800
- TS800NETS800/4
- TS800HETS800
- TS800HETS800/4

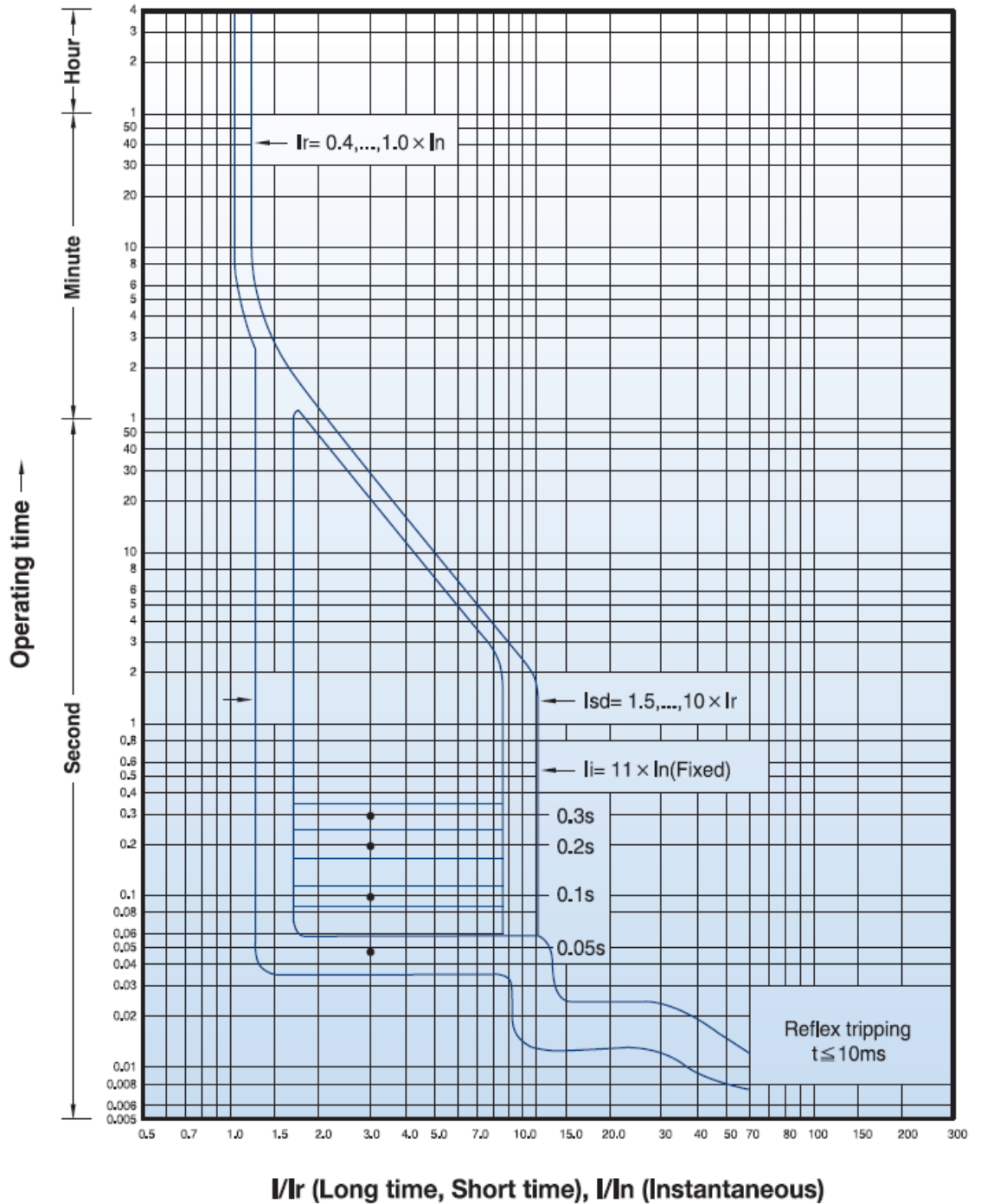

**TS400/630/800 ETM, Multifunction Electronic MCCB Setting Configuration**

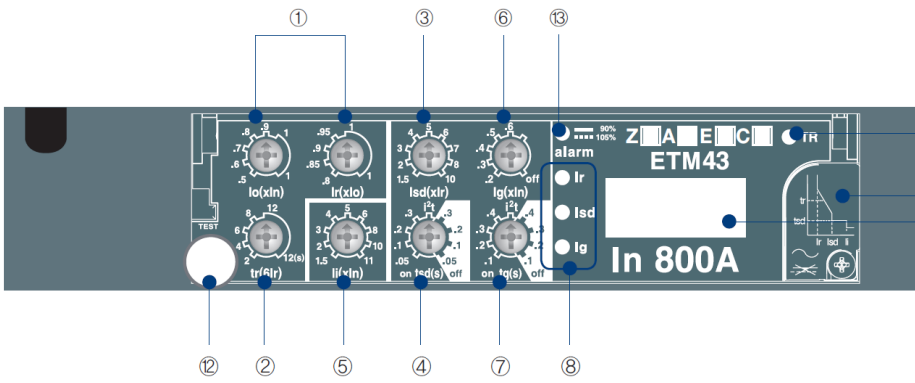
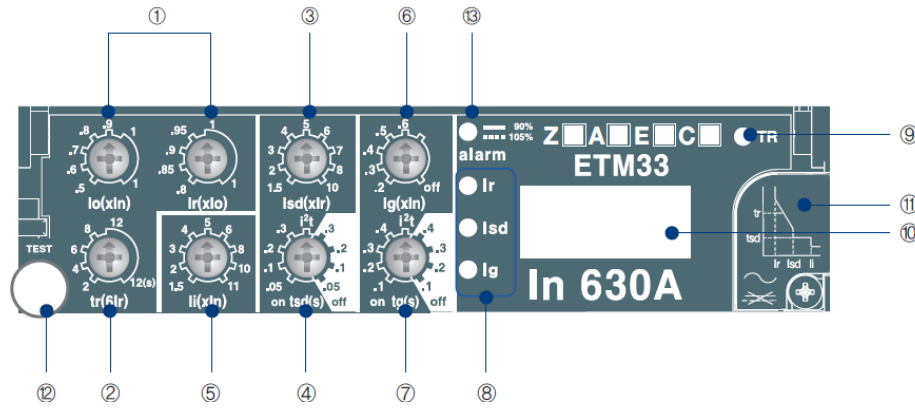

- 1 Adjustable rated current setting ( $I_r$ )
- 2 Adjustable long time setting ( $t_r$ )
- 3 Adjustable short time current setting ( $I_{sd}$ )
- 4 Adjustable time delay setting ( $t_{sd}$ )
- 5 Adjustable instantaneous current setting ( $I_i$ )
- 6 Adjustable earth fault current setting ( $I_g$ )
- 7 Adjustable earth fault delay setting ( $t_g$ )
- 8 Indication LED
- 9 TR (trip reason) button
- 10 Display LCD (Ammeter)
- 11 Battery
- 12 Test connector
- 13 Alarm LED 90%  $I_r$  : ON, 105%  $I_r$  or more: ON-OFF

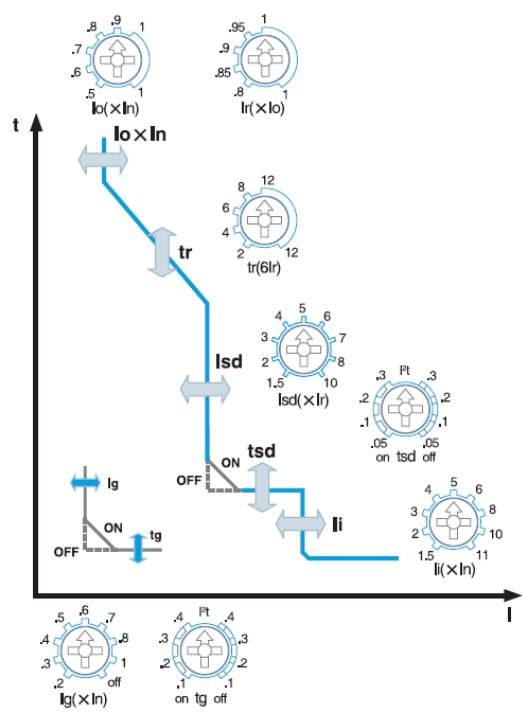

**Long time protection against overloads**  
 $I_o$  = Coarse adjustment (function of  $I_n$ )  
 $I_r$  = Fine adjustment  
 $t_r$  = Long time delay

**Short circuit protection**  
 $I_{sd}$  = Short circuit threshold,  
 $t_{sd}$  = Short circuit time delay  
 $I^2t$  curve in position ON or OFF

**Instantaneous protection**  
 $I_i$  = Instantaneous threshold

**Earth fault protection**  
 $I_g$  = Insulation fault threshold  
 $t_g$  = Earth fault time delay  
 $I^2t$  curve in position ON or OFF



Overload Protection (Long Time), Ir

Trip Unit Type		TS400	TS630	TS800
Trip Unit In(A)		400	630	800
Setting Value Coarse, Io	Setting value Fine, Ir	Short Time pick up current Setting, I <sub>sd</sub> = Setting Value(1.5-1.0)xI <sub>r</sub>		
0.5	0.8	160	252	320
	0.85	170	267.75	340
	9	1800	2835	3600
	0.95	190	299.25	380
	1	200	315	400
0.6	0.8	192	302.4	384
	0.85	204	321.3	408
	9	2160	3402	4320
	0.95	228	359.1	456
	1	240	378	480
0.7	0.8	224	352.8	448
	0.85	238	374.85	476
	9	2520	3969	5040
	0.95	266	418.95	532
	1	280	441	560
0.8	0.8	256	403.2	512
	0.85	272	428.4	544
	9	2880	4536	5760
	0.95	304	478.8	608
	1	320	504	640
0.9	0.8	288	453.6	576
	0.85	306	481.95	612
	9	3240	5103	6480
	0.95	342	538.65	684
	1	360	567	720
1	0.8	320	504	640
	0.85	340	535.5	680
	9	3600	5670	7200
	0.95	380	598.5	760
	1	400	630	800

Setting example :

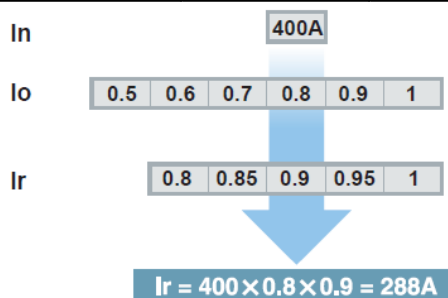

### Short Circuit Protection, $I_{sd}$ (A)

Setting example :

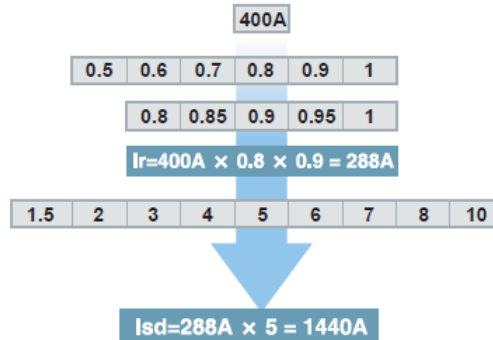

The breaker trips when the current exceeds 2880 A.

### Short circuit time delay, $t_{sd}$

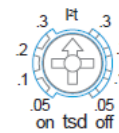
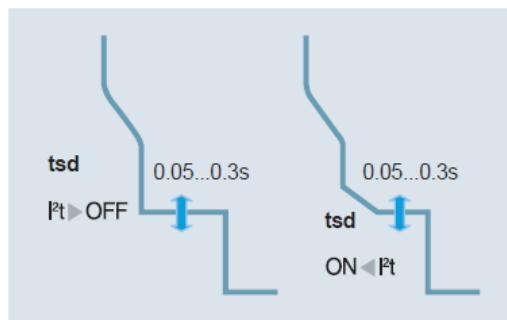

### Earth fault protection(E), optional

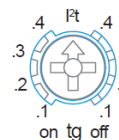
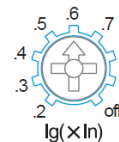
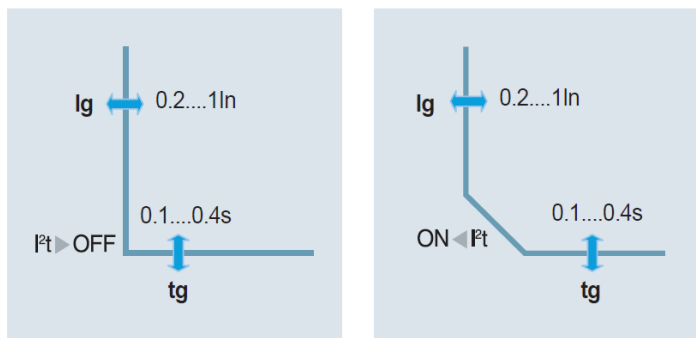

$I_g$  = insulation fault threshold  
 $t_g$  = earth fault time delay

### Optional units

The following optional units can be added to the ETM Electronic MCCB,

- **A-Ammeter (A)**; measure of current with an accuracy of  $\pm 10\%$ .
- **Z-Zone selective interlocking (ZSI)**; reduce stress on components during short-circuit or earth fault conditions, reduces tripping time and reduced damages caused by faults of interference to the power supply. **DC24V power supply required.**
- **C-Communication**; RS485 (Modbus-RTU) interface, connection available to all kinds of PLC and computers. Transmitted data; protection setting values, highest current of the three phases, "R, S, T and N" phase currents and fault reading (Overload, short-circuit, etc.).

**TS400/630/800 ETM Characteristic Curve**

- TS400NETM400
- TS400NETM400/4
- TS630NETM630
- TS630NETM630/4
- TS800NETM800
- TS800NETM800/4
- TS800HETM800
- TS800HETM800/4

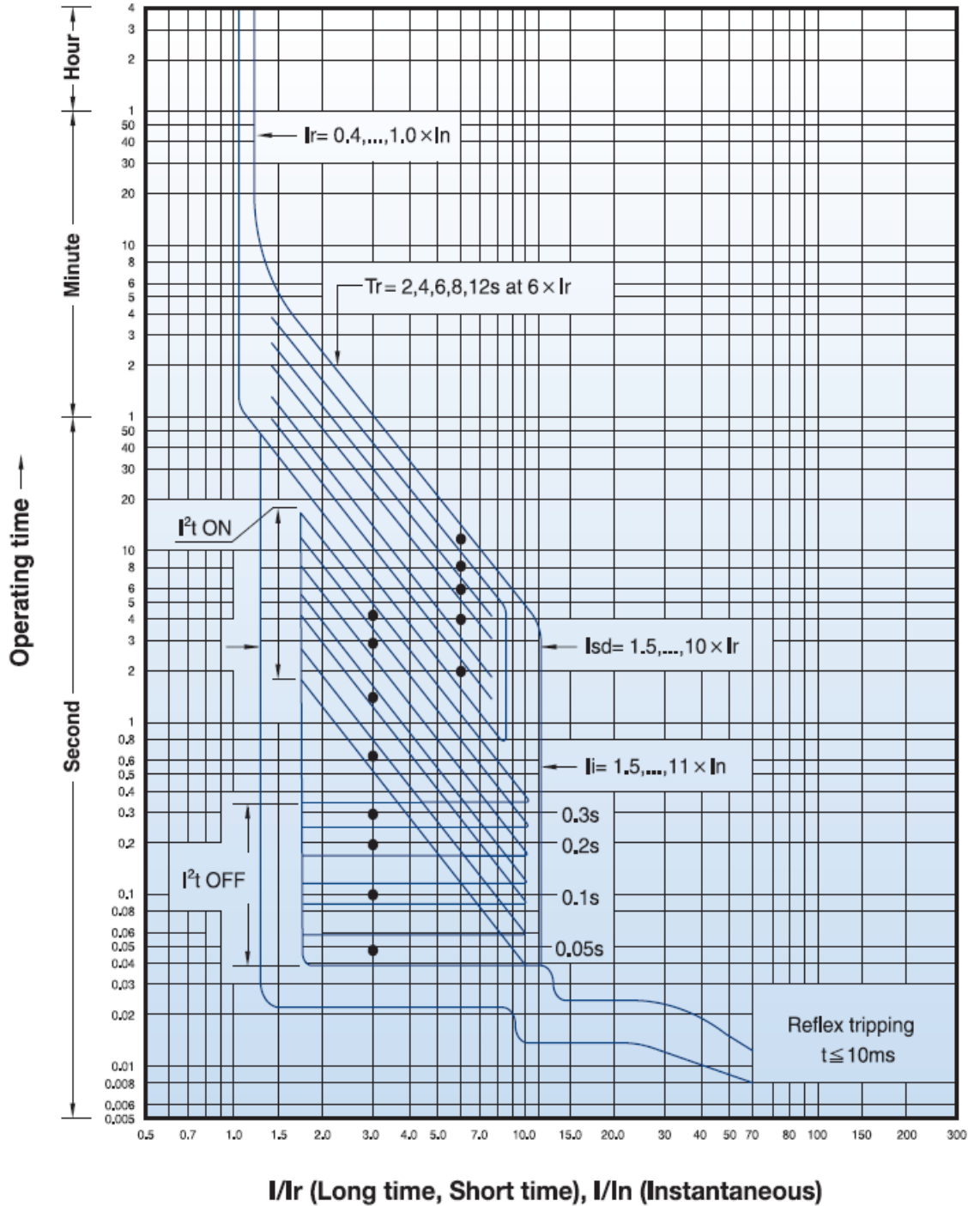

**TS400/630/800 ETM Ground Fault (G) Curve**

- TS400NETM400
- TS400NETM400/4
- TS630NETM630
- TS630NETM630/4
- TS800NETM800
- TS800NETM800/4
- TS800HETM800
- TS800HETM800/4

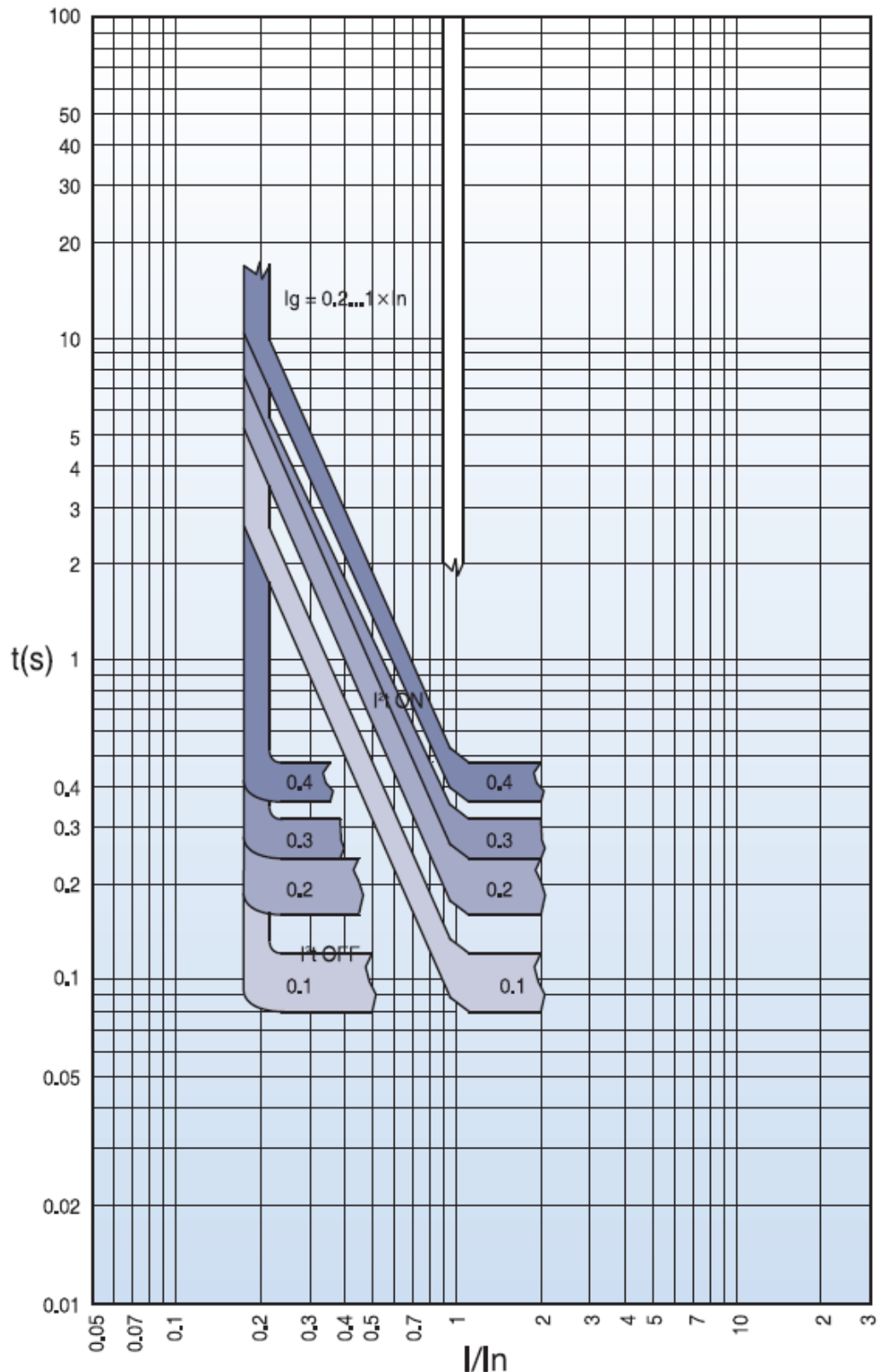

Catalogue number: **TS400/630/800 Range**

Thermal Magnetic and Electronic MCCB: 2,3,4 Pole 160A ~ 800A



**TS400/630 Overall Dimensions**

[mm]

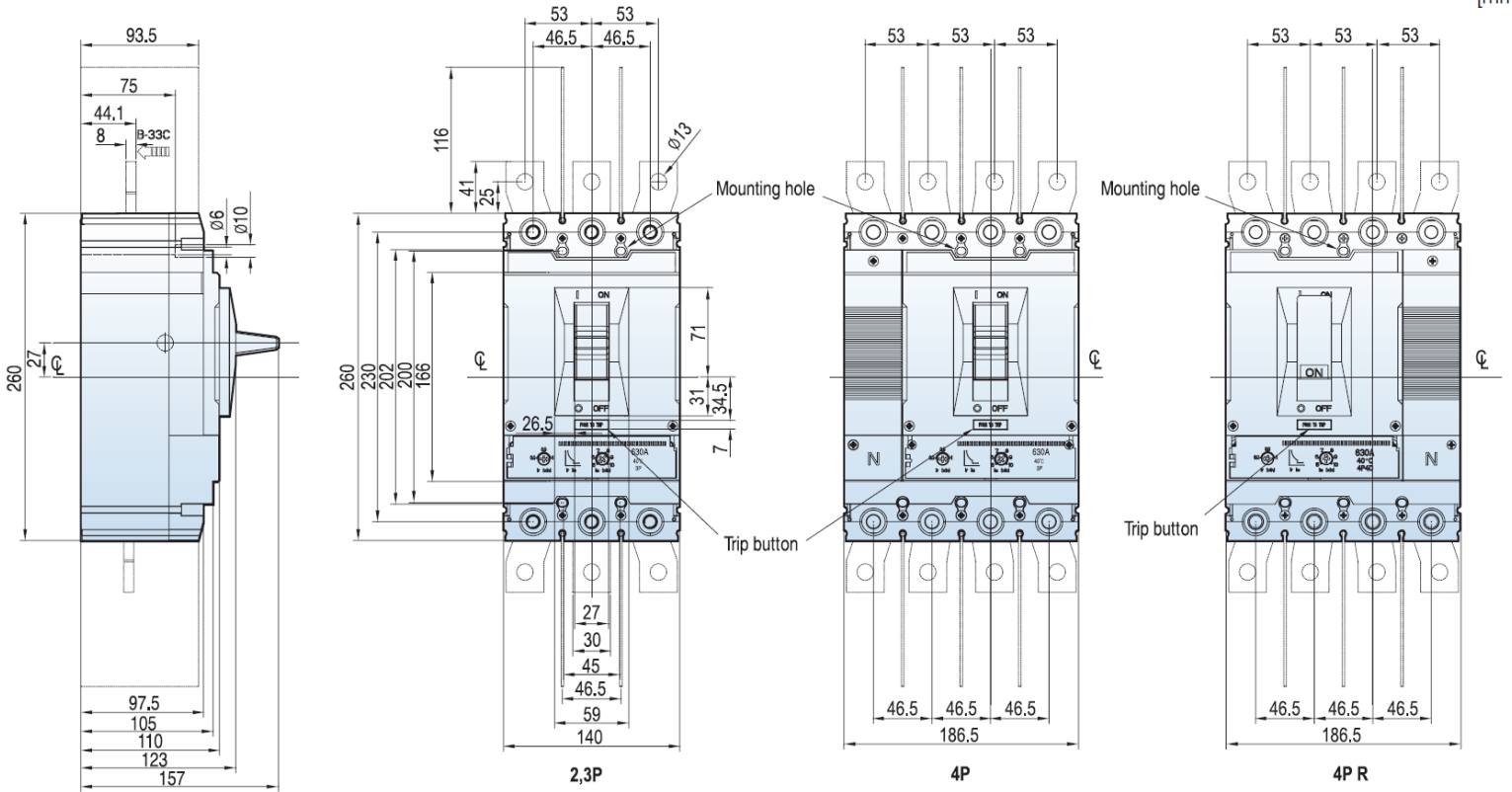

**Terminal section**

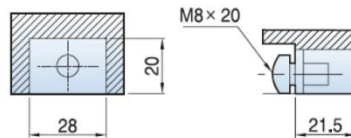

**Conductor**

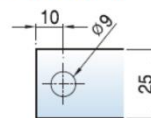

**Panel drilling**

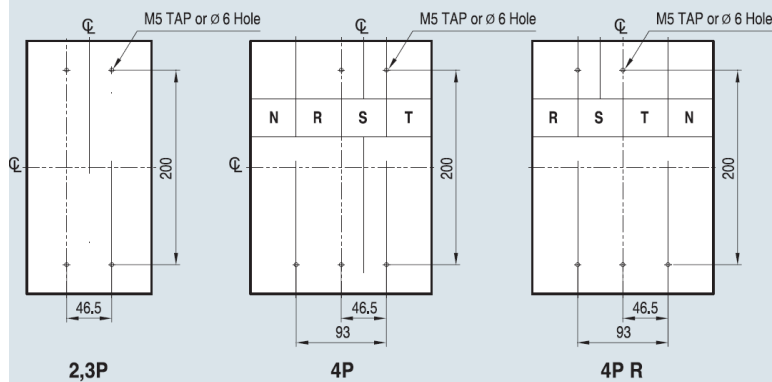

**Front panel cutting**

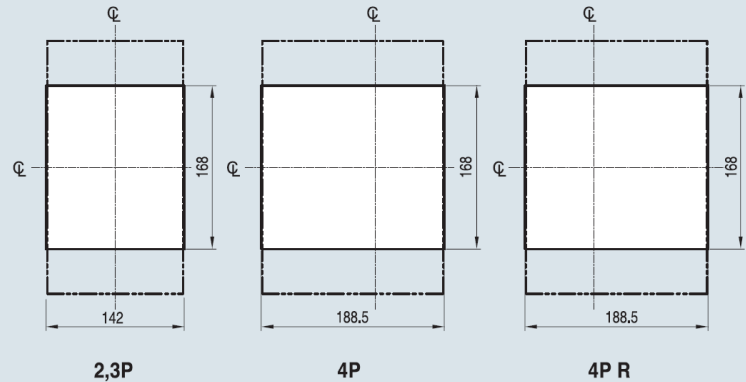

**TS800 Overall Dimensions**

[mm]

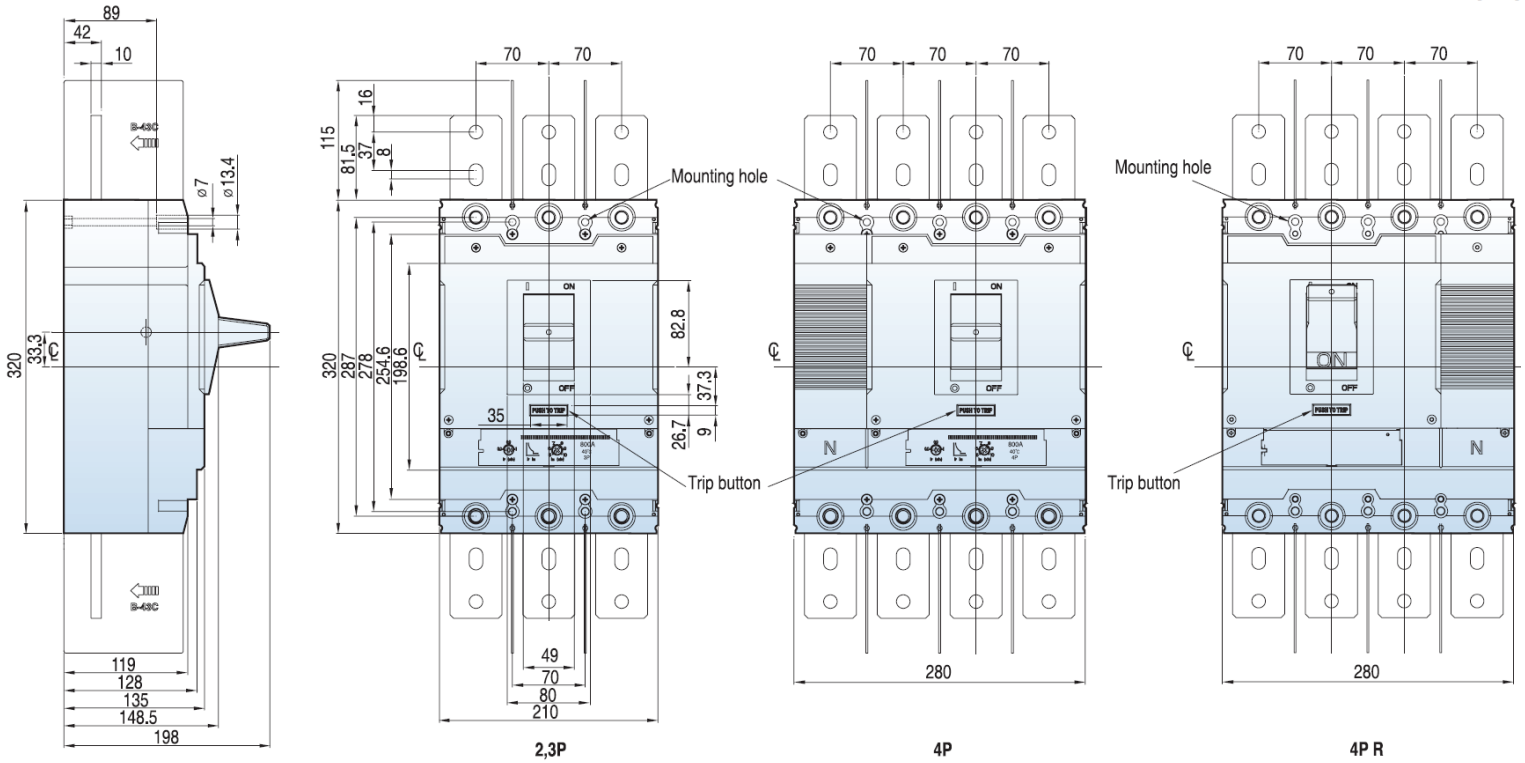

**Terminal section**

**Conductor**

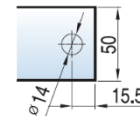
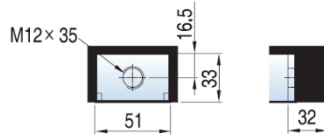

**Panel drilling**

**Front panel cutting**

