



Products Instructions

XLDQ3NX Series Automatic Transfer Switch

Thank you very much for using C.LIN brand Automatic Transfer Switch. Please read the product instructions before use.

Content

Notice	01
Using the process	02
Accessories	03
Product Identification	04
Dimension Drawings	07
Installation Steps	08
NX-A Controller	11
NX-B Controller	14
Working Mode	21
Troubleshooting and after -sale Service	24

Notice

Automatic Transfer Switch(The abbreviation is ATS),Please read manual before operate the device.

Dangerous

Please read manual before install or operate the ATS,The ATS is installed,adjusted, repaired& maintained by professionals.
The ATS are with many parts including PCB Board On-line voltage work, can not touch these parts,only use insulated tools.
Can not touch those who are not protected components or charged terminal on the screw.
In ATS line for maintenance,you should take the following protective measures.
-Cut off all power
-place the switch on a"No Closing "signs.
-Will be locked in off position switch.

WARNING

Patented products,imitation reserved

Nconsistency in the power-line voltage and configuration of ATS,you shouldensurethat the line voltage and the nameplate of the ATS expressed by thesupply voltage range to adapt to,if not always,it is possible damage to ATS
Not in accordance with manual operation would result in equipment damage.

Using the process

- **ATS delivery**

Check and confirm whether the products is the same type and model you ordered.

Remove the packaging to check and make sure the ATS without damage in the transport process.

- **Check voltage**

Check and confirm if the working voltage is matched with the ATS operating voltage range of your ordered.

- **Install ATS**

Install ATS according to this product instructions .

Install all of the outside option accessories .

- **Connect the ATS Equipment**

Connect bus-bars, then connect the controlling lines.

- **Set up**

Please set up the parameter for the ATS according to the instructions in the handbook.

Accessories

No.	Name	Quantity	Note
(1)	Manual.	1Piece	
(2)	Screw	1Set	(M8X20mm)48cs
(3)	European Model Terminal	Each piece	
(4)	European Model Termiinal	Each piece	"A"Type Controller with this Terminal

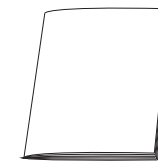

(1)

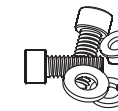

(2)

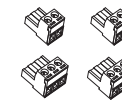

(3)



(4)

Notes:

#In the absence of or damage to any accessories, please contact the manufacturer.
#please save operating manuals to prepare for the future operational use.

Product identification

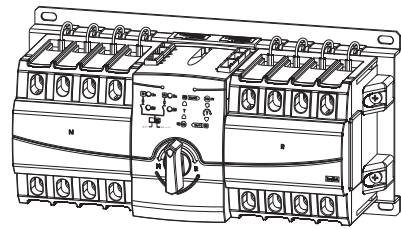

Isometric View

1. Product model
2. Product performance parameters
3. product marks
4. implementation standards
5. The current parameters for the product

The marks in XLDQ3NX series ATS products are as follows:

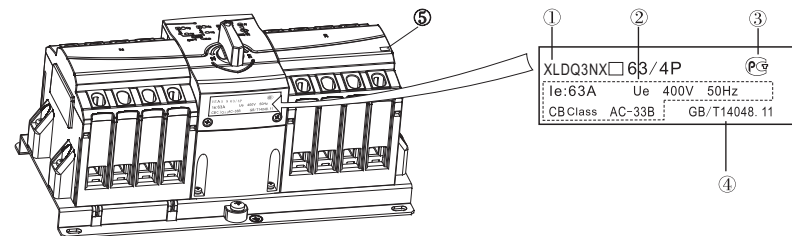

XLDQ3NX□63/4P
 Ie:63A Ue 400V 50Hz
 CB Class AC-33B GB/T14048.11

The Features and Functions for ATS Controllers:

Automatic transfer switch works from one main power to another reserved power according to the voltage state of the working voltage and the working mode set by the user, Its function depends on its configuration of the controller. There are model A controller and model B controller. The main function and characteristics are shown in the following table:

controller	A controller	B controller
working power supply	AC85-280V 50/60HZ	AC85-280V 50/60HZ
Installation method	Integrated form	Integrated form
Working position	2 working positions	3 working positions
Operation mode	automatic and manual	automatic and manual
generator control	/	connected with a set of 240V 5A relay
Fire linkage control	/	A set of passive contact input with a group of normally open power signal feedback contact

controller	A controller	B controller
Conversion mode	Automatic switch, automatic reset	Two mode for choice : Can be set: 1. Automatic switch and reset. 2. Automatic switch and manual reset and the power-generator mode .
Transfer delay function	Fixed 0.2 seconds	Adjustable for continuous 0~30 seconds
Returning delay function	Fixed 0.2 seconds	Adjustable for continuous 0~30 seconds

Dimension Drawings

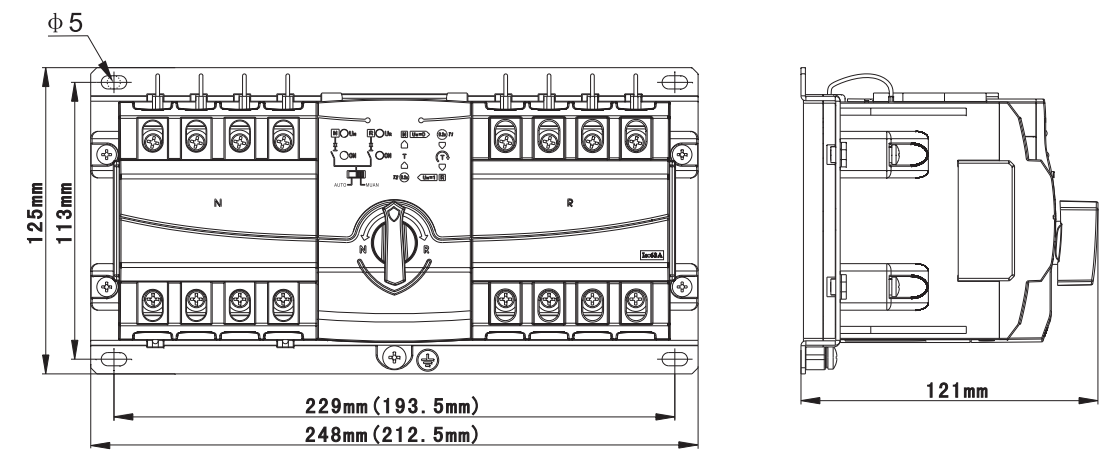

Note: the dimension of the drawing in brackets for three pole switch size

Installation Steps

Installation steps for XLDQ3NX series product

1. Fixed the switch body

According to the ATS dimensions drawing which manufacturer provides, please open 4 holes which are 5mm diameters in the installing board, then install to fix the ATS by screws.

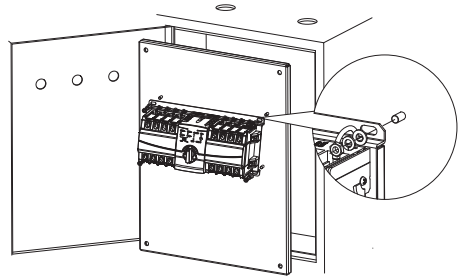

Install the screws or screw tapping suggestion mounting plate welded on themounting plate for easy maintenance.

08

2.Connect to the output terminal

When connecting, according to the grade of the ATS'S rated current, choose the suitable wires to connect the output terminals (A.B.C. N poles) of the two circuit breakers pole and fix the bus screws and tighten them with proper torque.

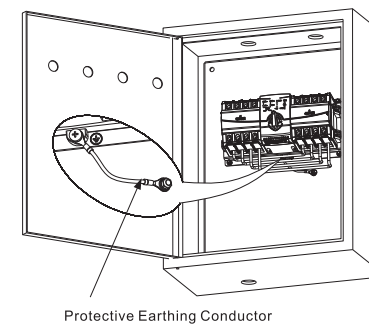
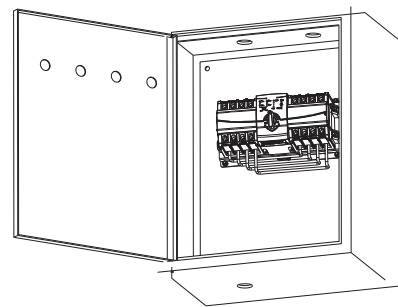

4.Bus bar installation

As shown in accordance with the left, Common Power Supply and Backup Power Supply are connected one the top of ATS respectively. The Load Bus is connected with Outgoing BUS of ATS secondly, Please kind note the phase sequence must be consistent with two way power when install.

3.Fixed with Protective Earthing Conductor

ATS has protective grounding in the top of the bolt, the installation of ATS should be the protection of gorund with the switch cabinet to cinnnect the protection esrth wire must be reliable to ensure that the operator safe.

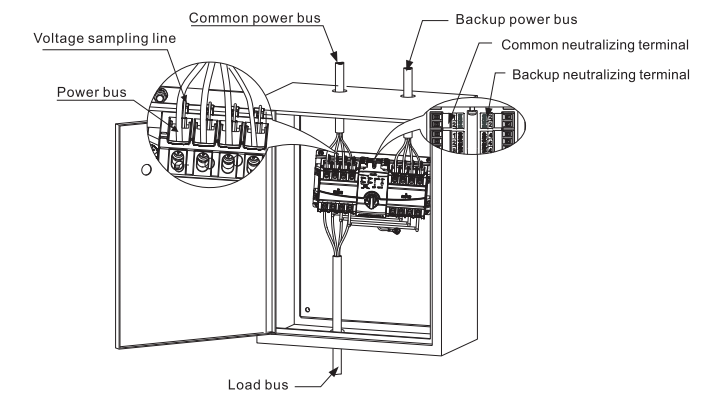

09

5. Install the external indicator

There are equipped with a common power indicator, a backup power indicator and circuit breaker closure indicator and the matching external output terminals (AC220v, 0.5A active power) for these above indicator signals on the ATS control panel. Users can choose your needed external indicator. For specific wiring method, please refer to the wiring terminal instruction of your controller type (A or B).

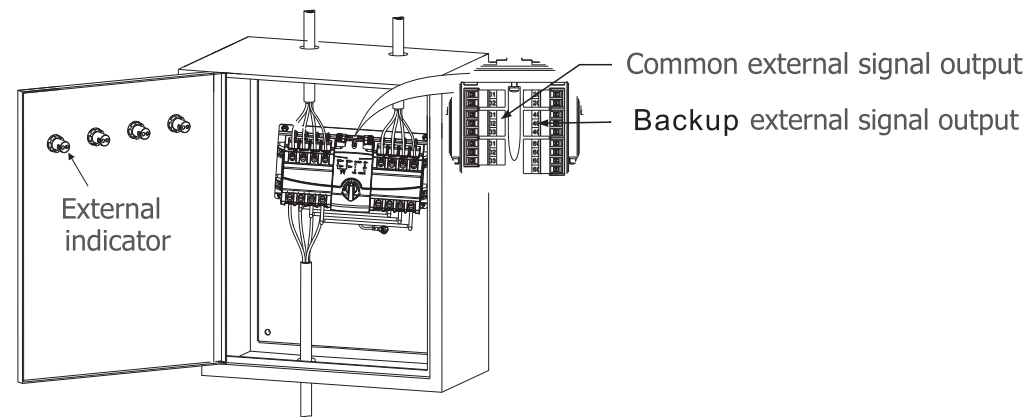

XLDQ3NX-A Controller

XLDQ3NX-A Controller is a simple type which is developed for meeting the demand of the market both in domestic and abroad. The Controller has the advantages of its simple operation, suitable function, visual display etc.

● The structure of the XLDQ3NXA Controller

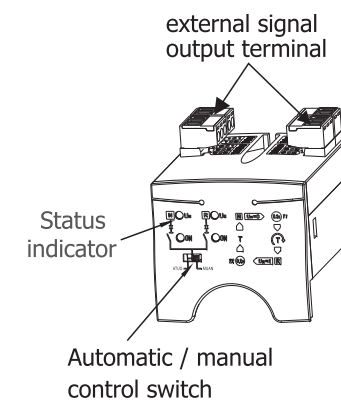

● Technical parameters

Operating Temperature: $-30^{\circ}\text{C} \sim +60^{\circ}\text{C}$
 Power Voltage Range: AC85V~300V
 Power Consumption: $\leq 5\text{W}$
 Transfer Delay: 0.2s
 Return Relay: 0.2s

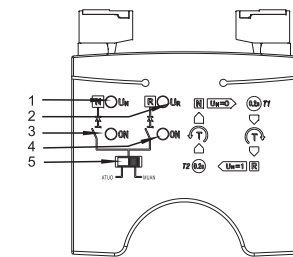

1. common power supply indicator
2. backup power supply indicator
3. common power supply "ON" indicator
4. backup power supply "ON" indicator
5. selected switch (AUTO/MANUAL)

The instructions for the terminal and wiring

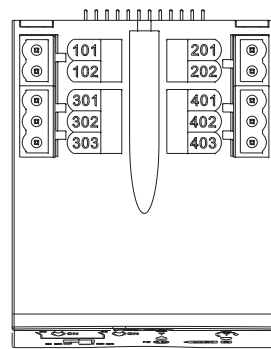

1. 101, 102 three-pole switch, common power null line terminal (connecting to any port is ok)
2. 201, 202 three-pole switch, backup power null line terminal (connecting to any port is ok)
3. 301~303 main power, external status indicator signal output (AC220v, 0.5A)
 - 301 - signal indicator common null line
 - 302 - common power signal output
 - 303 - common power supply switching signal output

4. 401~403 Backup power external status indicator signal output (AC220v, 0.5A)
 - 401 - signal indicator common null line
 - 402 - backup power supply signal output
 - 403 - backup power supply switch close signal output

Elementary diagram

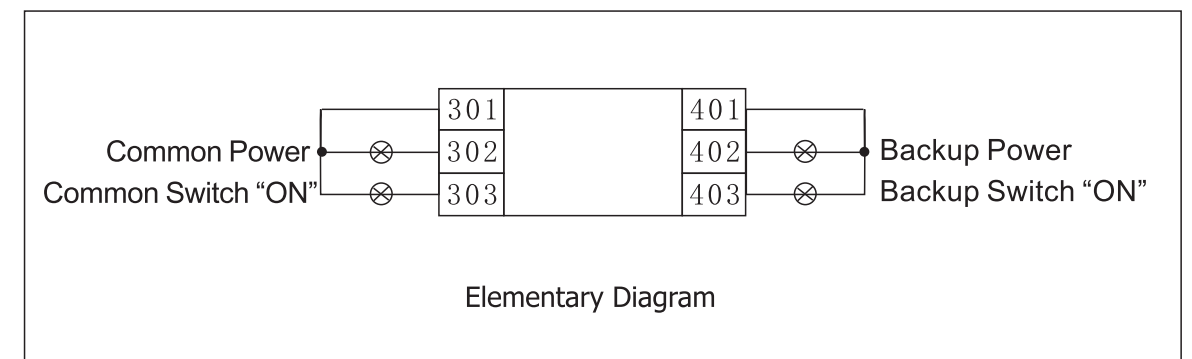

XLDQ3NX-B Controller

XLDQ3NX-B Controller is a multifunctional power control device which has the functions of measurement, analysis, control and protection etc.

Product Characteristics :

HATS-B controller can set working mode and switching parameters by setting controlling buttons. It has fire fighting linkage control function. The intelligent controller is made up of a set of passive fire protection signal input terminal. The signal input uses opto-coupler isolation making the HATS-B controller strong anti-interference ability. It also has a set of passive signal output feedback terminal which can make the switch received signal return to the fire fighting equipment. HATS-B controller has the generator start and stop control functions. Its relay node inside is responsible for controlling the start and stop of the generator.

Technical parameters:

Operating supply voltage range : AC 85~280V

Working temperature: -30+60 Centigrade

power dissipation: equal or less than 5W

Conversion delay time: 0.1s ~30s adjustable

Returning delay time: 0.1s ~30s adjustable

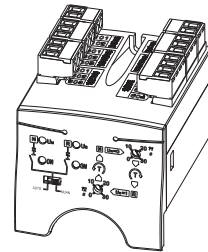

The terminal and wiring description:

1. 101, 102 three-pole switch, common power null line terminal (connecting to any port is ok)
2. 201, 202 three-pole switch, backup power null line terminal (connecting to any port is ok)
3. 301~303 common power, external status indicator signal output (AC220V 5A)
 - 301 - signal indicator common null line
 - 302 - common power signal output
 - 303 - common power supply switching signal output
4. 401~403 backup power external status indicator signal output (AC220V 5A)
 - 401 - signal indicator common null line
 - 402 - backup power supply signal output
 - 403 - backup power supply switch close signal output
5. 501-503 generator start control signal output terminal

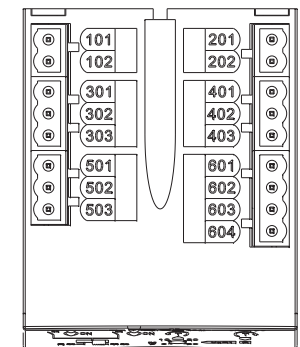

When the backup power is a self-starting generator, user can make automatic start generator function by connecting 501-503 terminal with the generator controller.
 The inner side of the 501-503 terminal is a group of passive relay node. 503 is relay common terminal, 501 is relay normally closed contact, 502 is normally open contact.
 When the common power supply is normal, 503 and 502 are closed, 503 and 501 open .
 If the common power failure and the reserved power supply is abnormal, then 503 and 502 are closed, meanwhile 503 and 501 break and give out motor starting signal, then the generator starts successfully and the ATS turn over automatically to the backup power side to supply power to the load.
 During the backup power supplies power to the load, if the common power recovers to normal state, then the controller will control the ATS to turn over and back to the common power automatically by the returning delay, at this time, the common circuit breaker is closed, then 503 and 502 will be closed after 3 seconds delay time, then 503 and 501 break and give the stop signal out.

6) 601-604 is fire linkage control terminal; the interface is used for cutting off the power supply by remote control as soon as the fire equipment alarms.
 601. 602 is fire linkage control signal input terminal, the external of this interface can only connect with a group of normally open passive contact (if fire fighting equipment sends an active signal, it must connect a small relay first to switch, then make the relay normally open contact connect to the controller, otherwise the controller will be burned), when the external contact closed, the controller will immediately control the ATS switch to the off position to make the load cut off, and then return the signal to the fire control center by 603 and 604 terminal .

603, 604-- is a group of normally open relay dry nodes, used for the fire action return signal. This terminal in normal state is normally open, 603 and 604 will be on when there is a fire signal that comes into the controller and the ATS switches to the off position .
 (Note: when the fire linkage function starts, the automatic switch will stop working. If we want the ATS to recover the normal switching state, we have to cancel the fire signal , then do one time switching by the automatic / manual switch on the panel so that the ATS will recover the normal switching state.

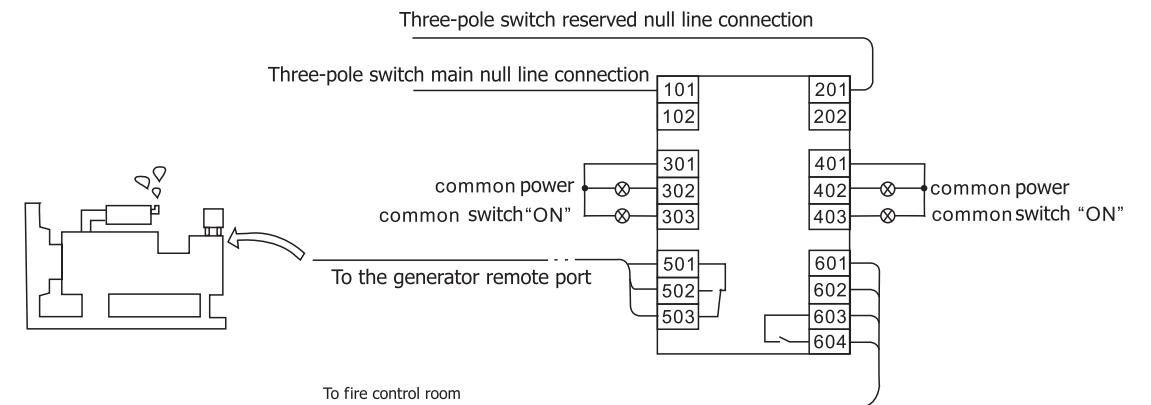

The functions of the control panel:

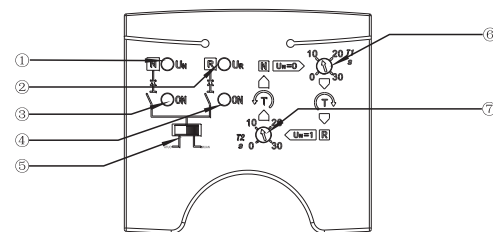

- (1) Common power normal indicator. When the voltage of the commonpower is in the normal state, this indicator lights.
- (2) Backup power normal indicator. When the voltage of the backup power is in the normal state, this indicator lights.
- (3) The common power closing indicator,When the switch is at the position of the common power, this indicator lights. When controller is in the state of returning delay, this indicator flashes.
- (4)The backup power closing indicator. When the switch is at the position of the backup power, this indicator lights. When controller is in the state of switching delay, this indicator flashes.
- (5) Automatic / manual conversion control switch, when the control switch in the left position, it is for the automatic conversion, in the right it is for the manual conversion.

- (6) Conversion delay time setting potentiometer (The delay time of the conversion from the commonpower to reserved power) When the switch is in the state of the common power closed position, if the common power failure and the backup power is normal, then the controller begins to counting time(the counting time is set by conversion delay time setting potentiometer), after finishing counting time, the controller will control the switch to convert to backup power for power supply. Make the delay time a little larger so that the controller can be avoided a big damage conversion from when the grid voltage decreases suddenly. (For example, the split-second voltage decrease situation comes from large motor start in the same grid network)
- (7) The returning delay time setting potentiometer (The delay time of the conversion from the backup power to common power) When the switch is in the state of the backup power closed position, if the common power recovers to the normal state, then the controller begins to counting time (the counting time is set by returning delay time potentiometer), after finishing counting time, the controller will control the switch to convert to common power for power supply.

Inspections before the power on:

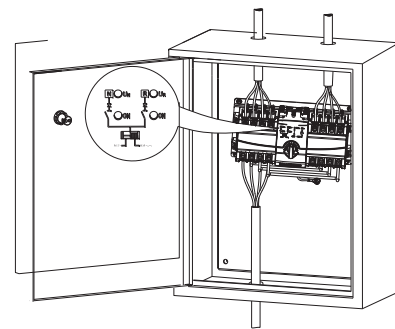

After you finished the ATS wiring working, you are request to have a inspection on the installations to prevent the errors coming.

1. Inspect if it is right about the installation and wiring on the ATS, especially to check the main wiring terminals, such as the power bus.
2. Inspect the connection of the external signal indicator is right or not, to see if there is short circuit.
3. Inspect if the bus screw is reliable or not, tightened or not.
4. For the first time's power-on debugging, please make the load disconnected.

When all the above inspections passed and confirmed there is no erroneous operation, then you can make the power on and do debugging using.

Working Mode Automatical operation mode

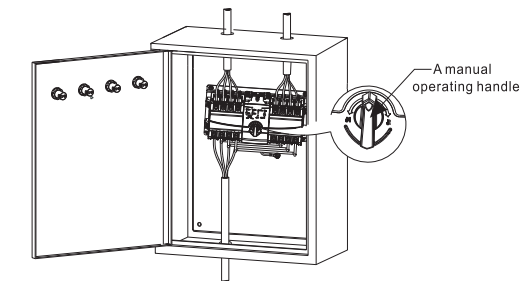

For usual use, we should put the automatic / manual control switch on the automatic position. When choosing the automatic control way, the controller does testing on the common power and backup power at the same time, if the common power failure and the backup power is normal, ATS does automatic conversion to make the load switch from the common power to the backup power after conversion delay time. And when the common power recovers to normal state, the ATS automatically returns back to the common power by returning delay time.

Manual operation mode

For special circumstances when we need to do manual switching, put the automatic/manual switch on the manual position first, then use the operating handle on the switch to do manual conversion.

manual operation handle

In the manual operation mode, when rotating the switch handle with counterclockwise, the switch returns back to the common power position. If do clockwise rotation, the switch returns back to backup power position. If need automatic conversion, we should turn the automatic/manual control switch over back to the automatic position.

When the fault trip occurs (when the power is normal, the switch is on the closed position, but no power is output), first check and confirm if it is fault load. If not, use the operation handle to turn the ATS to dual-off position, and then turn manual/auto control switch onto the automatic position. By doing so, the ATS will come back to the normal and automatic operation state.

Troubleshooting and after-sale service

● System maintenance

In order to ensure the ATS runs stably and reliably, You'd better to make switching experiments regularly (every three months) to make sure the switch works normally, and supply the load continually.

The common troubleshooting

When the ATS can not switch smoothly, please refer to the following table tips for troubleshooting. If refers to the solution from the below table, the problem still can not be solved, please contact with our company or your local distributors.

Symptom	troubleshooting	fault resolution
Power on but the indicator doesn't light	Check if the power sampling line is off	Make the corresponding line connected
	3-pole switch's system neutral line hasn't been connected to neutral terminal.	
The controller displays normally but the switch can not do normal conversion.	Check if the controller is at the manual operation position	Put the controller in the automatic gear shifting
The power is normal, switch in the closed position, but the load end has no power.	check whether the switch is tripping.	After eliminating the load failure, then make the switch buckle manually.

● **Warranty and after- sale Service**

This product is manufactured under the perfect quality management system. In case of failure, our company supplies product warranty and after-sale service. Please read the following statement:

The ATS switch body should be checked and maintained regularly according to the requirement of the selected Circuit breaker and the electric operating mechanism. For long-term without being used product, pay attention to take precautions against rust, moisture. Before use, please debug the ATS according to the above operation instruction, if all is normal, then begin to operate.

Warranty period:

When the user complies with the custody and use conditions, our company is responsible for three guarantees for our products (guaranteed repairing, replacement, taking back the product) within 12 months since the product is used. (but not more than 18 months from the date of the delivery) During the three-guarantees period, the user is requested to debug, use and maintain the ATS according to product instruction. But the seal of the ATS must be kept intact. If the quality problems make the product not to be used in normally ,our company supply maintenance and replacement in free for the users.

However, if the failure due to the following causes, even in the warranty period, our company also can only provide paid repair or replacement.

If the damage results from user self- modified or inappropriate repair .

. Exceed the standard and criterion to use.

The fall and damage occurred after the purchase or during installation.

Earthquake, fire, lightning, abnormal voltage, other natural disasters and secondary disaster causing the product cannot be used.