 Zhejiang Famous Trademark National Hi-tech Enterprise

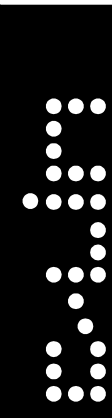

Clin

XINLING ELECTRICAL CO., LTD.
Address: Zhiguang Industrial Zone, Liushi Town, Yueqing
City, Zhejiang Province, China
Tel: 86-577-62779963



Zhejiang Famous Trademark
National Hi-tech Enterprise

Clin

Products Instructions

XLDS3

Automatic Transfer Switch / User Manual

Thank you very much for using Clin brand automatic transfer switch. Please read the products instruction carefully before use!

Contents

Foreword.....	1
1、 Summary.....	2
2、 Standard.....	2
3、 Use Environment.....	3
4、 EMC Electromagnetic Compatibility.....	3
5、 Model Definition.....	4
6、 Technical Data.....	5
7、 Function Description	6
8、 Structure Introduction and Outline Drawing.....	7
9、 Control System Introduction.....	10
10、 Wiring Instruction.....	18
11、 Common Faults and Solutions.....	19
12、 Quality Assurance and After-sale Service.....	19

Foreword

Thanks for using our company products. We will provide reliable quality and dedicated service to allow you to rest assured to use our company products. Before installation, circuit connection, running and maintenance, please make sure to read carefully the user manual, to ensure the correct using, during using please also make sure know very well of relative safety and caution items.

Product Using Notes:

- 1) This device product only allows professional person to install, commissioning and maintenance.
- 2) Before installation, commissioning and maintenance must cut off the two power sources.
- 3) Must use voltmeter to check to make sure the power is cut off.
- 4) The device must be reliable earthed as per requirement.
- 5) Before device electrify have to reset the panel door and arc shield.
- 6) Illegal operations may result in electric shock, fire or explosion.

1.Summary

XLDS3 Automatic Transfer Switch is a PC class three-section automatic transfer switching device, mainly used for operating and transfer between two power supply system (Main power and Backup power) with AC 50Hz, rated voltage 400V and below, rated working current up to 630A. Its particular power monitoring device can detect the difference of two power source, and make transfer between two power sources when it match the transfer conditions, and also can send generator start and stop control signal as per requirement.

High short time withstand capacity, high short circuit making capacity

Adopt high density silver alloy contact, can withstand thousands operating circles without burning loss, pit or melting. No need daily contact maintenance, can continuously loading 100% rated current. Contact system adopt bridge type double break rotation insert structure, to reach the high short time withstand current capacity and high short circuit making capacity, no need special SCPD, no influence to the selectivity of inside circuit, and meanwhile also can match the application on the side of big capacity power supply. 10Ie making and breaking capacity, match the AC-33B use category

Optimized magnetic blow-out arc extinguish system, easily reach 10Ie making and breaking capacity, match AC-33B use category and also match the load property of AC typical application as per GB/T 14048.11 standard, have wide application range. Stacking structure, small volume

Main, backup power switch part adopt modularize design, stacking arrangement; make the product volume smaller than other similar products.

Three position with isolation lock

With "Main power position", "OFF position", "Backup power position" three working position, can used for fire linkage and high inductive impedance load; OFF position with isolation lock function, can meet the isolation requirement during the load side maintenance.

Display controller can integrated installation, also can split installation

Display controller and transfer controller split set up, display controller can install on the switch body panel (Integrated type), also can install separately on the door panel of switchgear box (split type), convenient for user to check and control of the ATS status.

Multi-functions, different modes

Controller have under-voltage, over-voltage, phase missing automatic transfer function and motor-driven forced transfer function, Auto mode have auto transfer with auto recovery and auto transfer without auto recovery two modes, to fit with different location; Have fire linkage function, to cutoff the load power under emergency situation.

2.Standard

GB/T14048.11-2008 Low voltage switch equipment and control equipment:multi-funtional transfer switch equipment (have passed CCC qualification test)

(2)

3.Use Environment

Ambient temperature:

-5℃~+40℃; 24hours average not more than +35℃;

Air Humidity:

not more than 50% at max. +40℃, max. Month humidity 90%, higher humidity is allowed at lower temperature. It should take special treatment for the occasionally condensation due to the temperature variation.

Altitude: Not more than 2000m

Pollution Class: The installation site environment pollution Class 3

Use category: AC-33B

4.EMC Electromagnetic Compatibility

General requirement: B class (common use)

Transmit Test:

Radio Frequency Transmission Test: as per GB4824-2004

Radio-frequency radiation Transmit test: as per GB4824-2004

Anti-interference Test

Static Discharge: air discharge class 4; contact discharge class 3 as per GB1762

Radio-frequency electromagnetic field: Class 3 as per GB17626.3-2006 and GB17626.6-2006

Fast transient pulse group: Class 4 as per GB17626.4-2008

Surge: Class 4 as per GB17626.5-2008

Short time voltage drop and voltage off: passed

3)

5. Model and Define

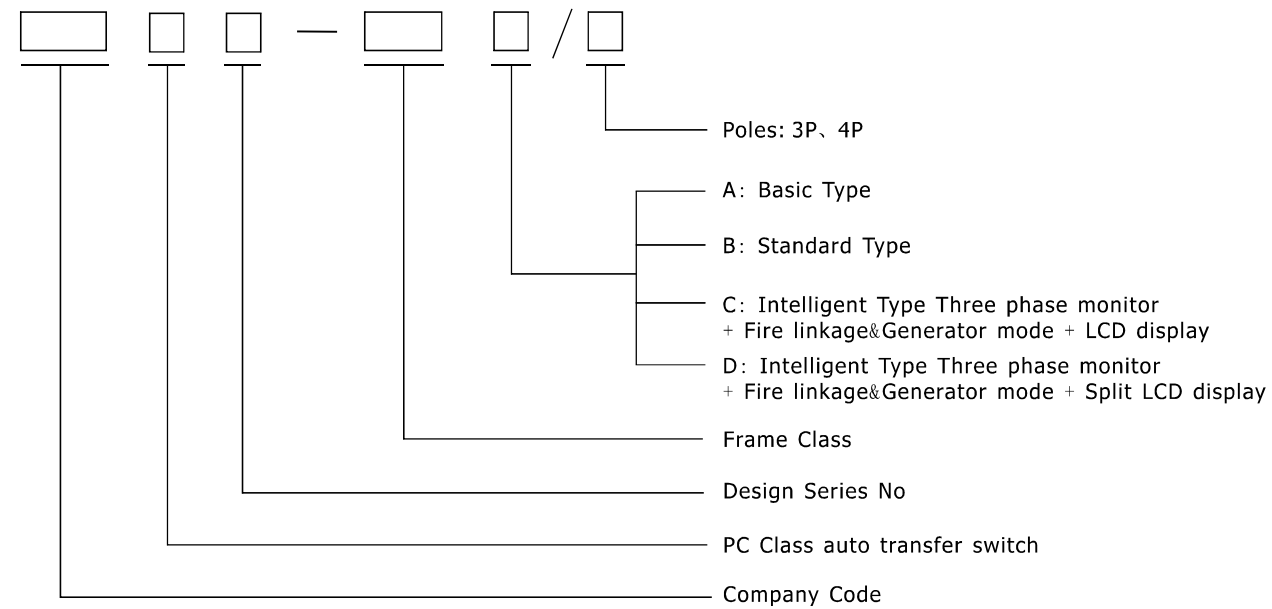

6. Technical Data

XLDS3 Automatic Transfer Switch	XLDS3-125	XLDS3-250	XLDS3-630	
Poles	3P/4P	3P/4P	3P/4P	
Rated Working current (A) Ie	16-125	140-250	315-630	
Rated working voltage (V) Ue	400			
Rated insulation voltage (V)Ui	800			
Rated impulse withstand voltage (KV) Uimp	8			
Use category	AC-33B			
Rated short time withstand current(KA, rms)Icw	10KA (200mS)	10KA (200mS)	25KA (200mS)	
Rated short circuit Making capacity (KA peak)Icm	20KA	30KA	50KA	
Rated limit short circuit current (KA)Iq	120KA			
Rated control power supply voltage (V) Us	230V/50Hz			
Contact transfer time (s)	1.5	1.8	2	
Operation cycles	no electricify	8500	7000	3000
	with electricify	1500	1000	1000
	Total	10000	8000	4000
Outline size (mm) WxDxH	245×130×122	295×175×175	430×272×228	
Weight (kg)	5	10	20	

7.Functions Description

XLDS3 Automatic Transfer Switch Functions

XLDS3 ATS Controller	A type Controller	B type Controller	C type Controller	D type Controller
Control power voltage	AC230V/50Hz			
Auto Transfer	Auto transfer with auto recovery	Auto transfer auto recovery, auto transfer without auto recovery, Power grid-Generator mode		
Manual Transfer	Manual main power, manual backup power, manual OFF			
Isolation Lock	OFF position with isolation function and also can with padlock locking			
Generator control	—	Generator start and stop		
Fire linkage	—	with passive(no Power) signal fire linkage to cutoff the device, with one set of passive(no power) feedback contact		
Display mode	Mechanical Indicate: Device ON and OFF status, Operation mode LED: Device ON and OFF status, power status		Mechanical Indicate: Device ON and OFF status, Operation mode LCD: Device ON and OFF status, power status	
Setting mode	A phase voltage monitoring		Key-press operation, English display interface, can set the working mode, low-voltage value, over-voltage value, delay time, auto transfer mode etc.	
Power monitor	—	ABC three phase over-voltage 265V ABC three phase under-voltage 187V ABC three phase voltage missing monitor	ABC three phase over-voltage (240-290V adjustable) ABC three phase low-voltage (150-200V adjustable) ABC three phase voltage missing monitor	
Delay time	—		Transfer delay (0-300s adjustable) Recovery delay (0-300s adjustable) Generator start, stop delay (0-300s adjustable)	
Mounting mode	Integrated mounting			Split mounting

Note: B type controller if need auto transfer without auto recovery mode, please specify when ordering.

8.structure introduction and outline size drawing

▲ Structure Introduce

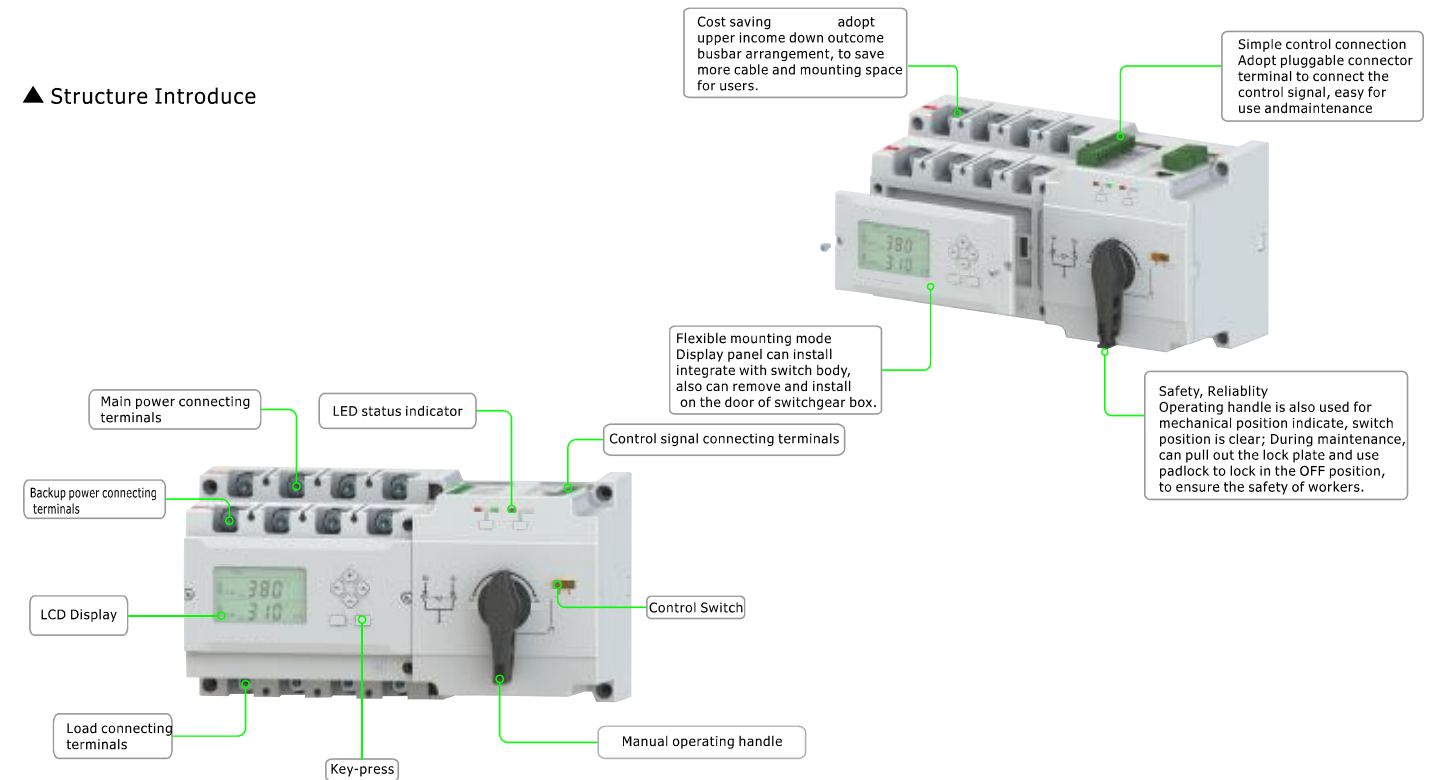

▲ Outline size drawing

XLDS3-125 (3P,4P outline and mounting size same)

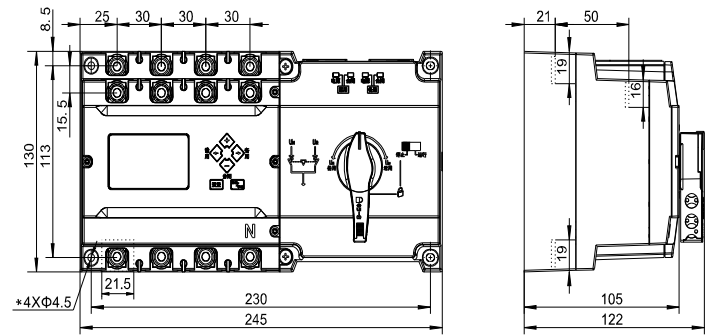

XLDS3-250 (3P,4P outline and mounting size same)

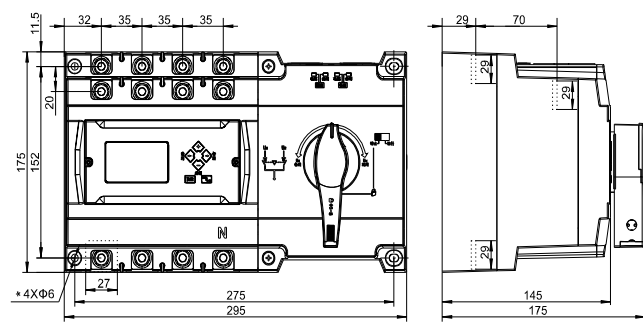

XLDS3-630 (3P,4P outline and mounting size same)

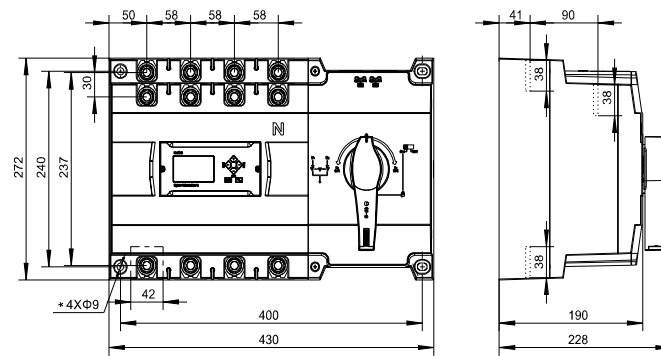

Display controller outline and split mounting hole size

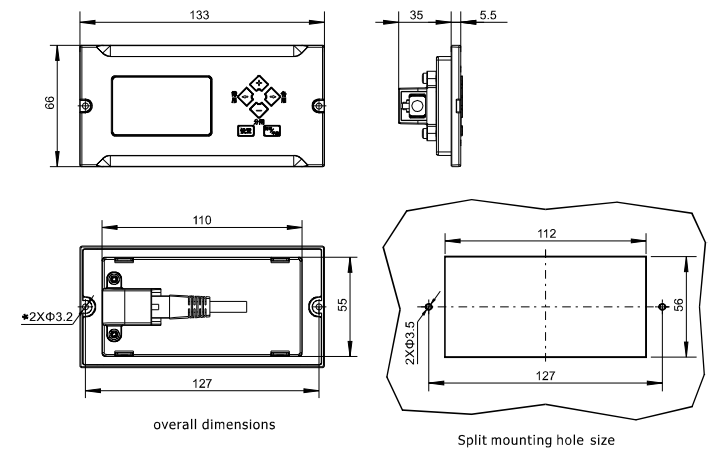

9. Control system introduction

▲ Controller functions

1. Under-voltage detection

Controller makes under-voltage detection for main power and backup power, when the under-voltage is detected with the power supply, it will start the auto transfer function to transfer to another normal power supply. When the power supply voltage is detected recovered to acceptable range (Recovery value), controller will decide whether make transfer according to the setted transfer mode and also can set transfer delay time.

2. Over-voltage detection

Controller makes over-voltage detection for main power and backup power, when the over-voltage is detected with the power supply, it will start the auto transfer function to transfer to another power supply. When the power supply voltage is detected recovered to acceptable range (Recovery value), controller will decide whether make transfer according to the setted transfer mode and also can set transfer delay time.

3. Transfer delay

When the main power is confirmed abnormal and backup normal, transfer delay start delay counting, after time delay is over then transfer from the main power to backup power. This time delay can wait to confirm whether the main power is short time abnormal, also can avoid switch frequently transfer.

4. Recovery delay

Recovery delay is after with backup power supply, and main power is confirmed available, then start delay counting, when delay time is over then transfer from the backup power to main power. This delay time can wait the main power supply output stable before it supply to the load.

5. Generator start delay

Generator start delay can avoid starting genset due to short time power off. When main power fault then start delay counting, and after the delay time is over then send generator start signal.

(Note: when the main power suddenly cutoff and genset didn't start, under this situation it can't delay due to no power supply to the controller, if need to use this function have to connect a DC24V aux. power supply to the controller to achieve the time delay function)

- Generator stop delay

Generator stop delay can remain the generator in hot backup status after it stop power supply to the load, avoid the genset restarting due to main power in short time recovery. When transfer from the backup power to main power supply then start the delay counting, after delay time counting is over then controller send genset stop signal.

- Transfer mode

Controller provides different transfer mode function according to the power supply property.

1: Power grid - Power grid:

At the application of power grid - power grid, ATS can provide auto transfer with auto recovery and auto transfer without auto recovery two transfer mode.

- Power grid - power grid auto transfer with auto recovery mode

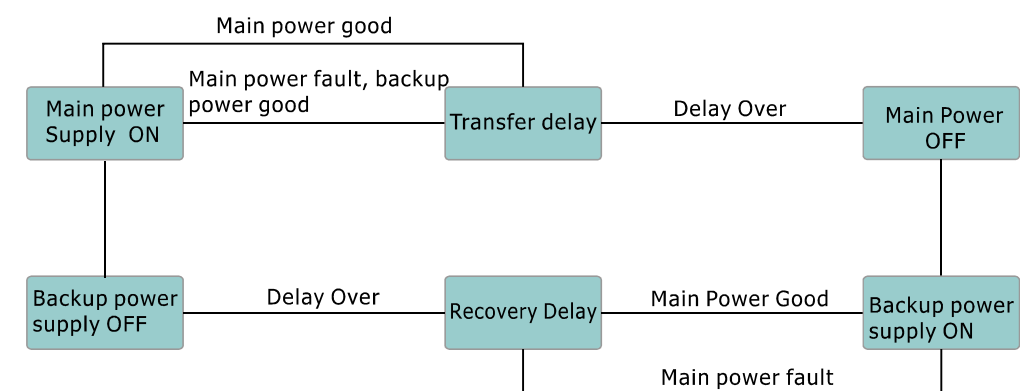

Power grid - power grid auto transfer without auto recovery mode

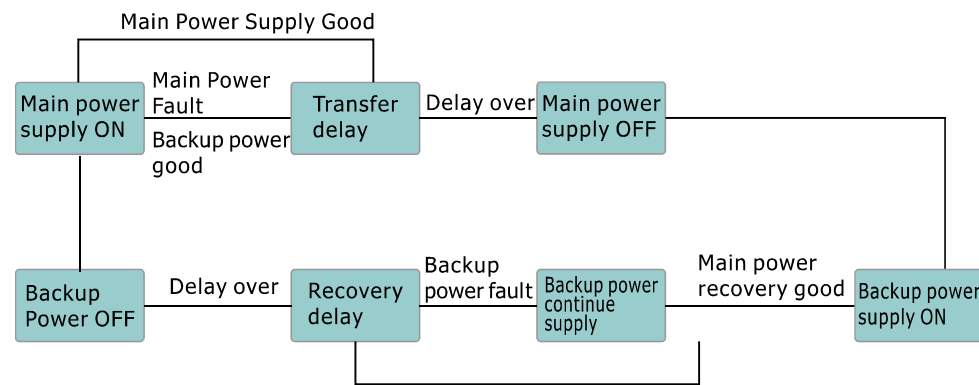

2: Power grid - generator mode
Transfer between power grid and generator

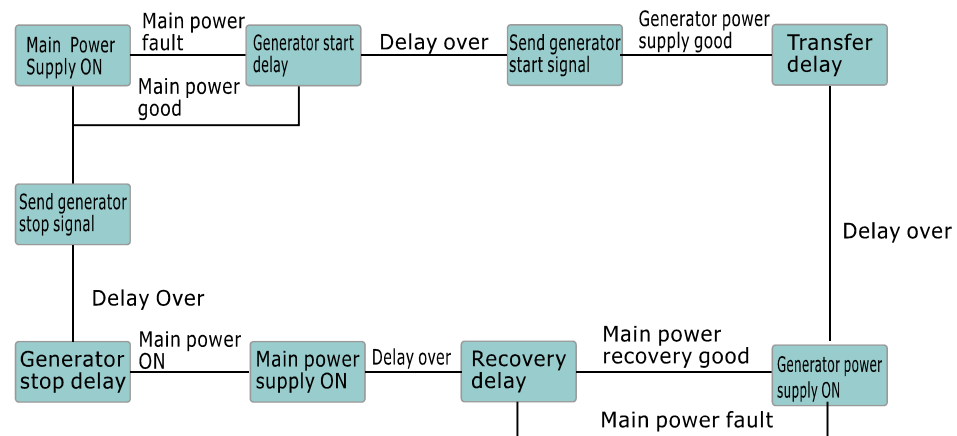

- 1: Auto、Manual working mode indicate;
- 2: Setting status indicate;
- 3: Generator start signal indicate;
- 4: Fire linkage function start indicate(ATS will stop when fire linkage start);
- 5: Main power status data indication zone: during working status display main power voltage data and transfer delay time, during setting status display setting item code;
- 6: Backup power status data indication zone: during working status display backup power voltage data and recovery delay time, during setting status display setting item code;
- 7: Setting button: press this button will enter into controller setting menu;
- 8: Auto/Manual transfer mode selection button: under working status it used to select the Auto and Manual transfer mode, under the setting status it used as save and escape function
- 9: Trip button: under manual control mode if any one of the two power is good, push this button will change to OFF position; under setting status it is used for data decrease button.
- 10: Main power transfer button: under manual control mode and main power good, push this button will forced to transfer to main power; Under setting status, it used for up page button;
- 11: Backup power transfer button: under manual control mode and backup power good, push this button will forced to transfer to backup power; Under setting status, it used for down page button;
- 12: + button: under setting status this button is used as data increase button;

XLDS3 Auto Transfer Switch Display Panel

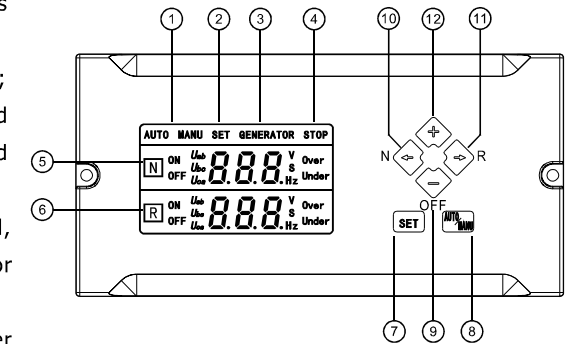

N=Normal Power (Main Power)
R=Reserve Power (Backup Power)

▲ Intelligent Controller Operation Instruction

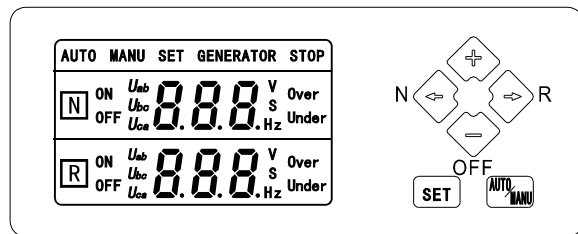

N=Normal Power (Main Power)
R=Reserve Power (Backup Power)

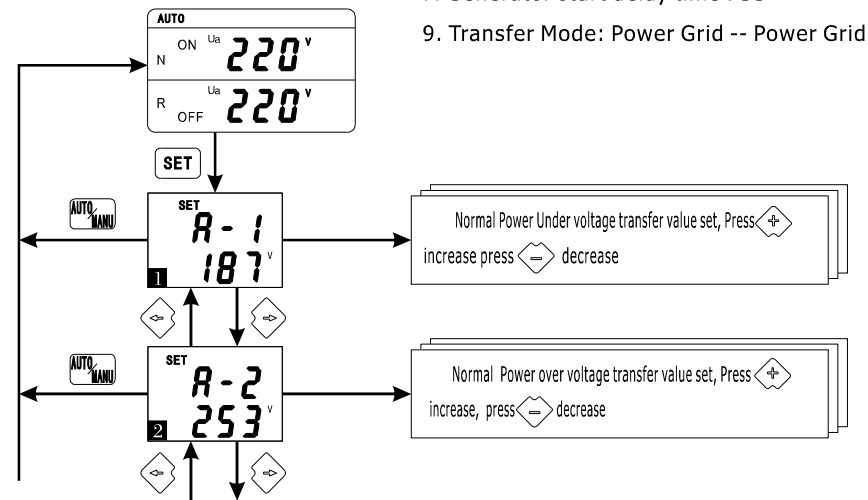

In order for user easy to use, the product have provide some frequently used transfer data for users to modify, these data before the switch leave factory have been proceed with default setting, the default setting data as followings:

1. Normal power under voltage transfer value: 187V
2. Normal power Over voltage transfer value: 253V
3. Reserve power under voltage transfer value: 187V
4. Reserve power Over voltage transfer value: 253V
5. Transfer delay time: 5S
6. Recovery delay time: 5S
7. Generator start delay time : 5S
8. Generator Stop delay time: 5S
9. Transfer Mode: Power Grid -- Power Grid

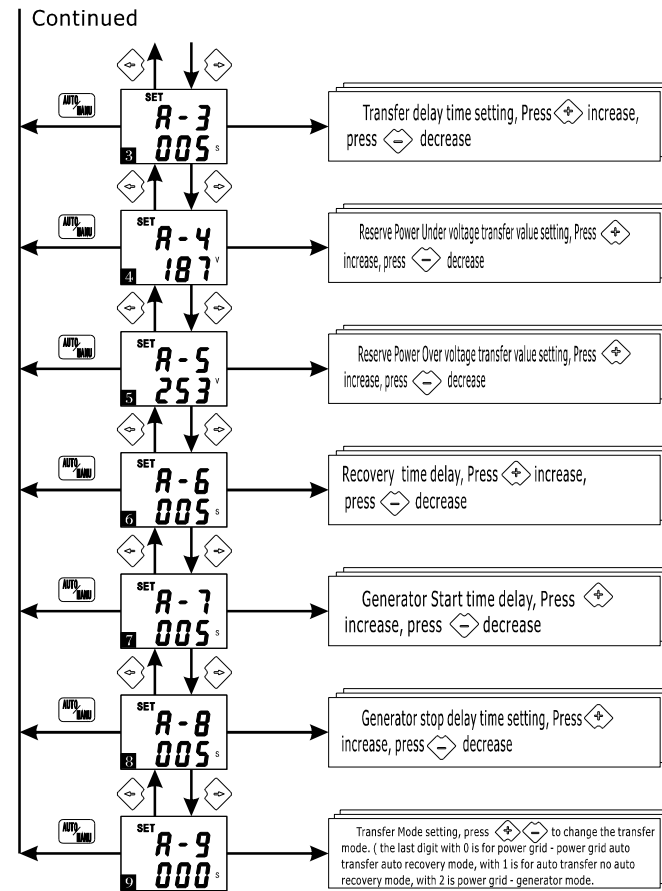

■ Key-press instruction

When controller is working, press Set button, LCD display setting interface as picture above, under setting menu, press “<” “>” button can up-page and down-page setting item, if press “AUTO/MANU” button will escape setting menu; press “+” “-” button can modify the data value.

10. Wiring Instruction

Controller Terminals and Wiring Instruction 101-103 : Main Power external Indicator signal output (Active AC230V 0.5A)

101—Indicator common null line

102—Main power indicator signal output

103—Main power ON signal output

201~203: Backup power external indicator signal (Active AC230V/0.5A)

201—Indicator common null line

202—Backup power indicator signal output

203—Backup power ON signal output

301~302 aux. power input (DC15V~24V/0.5A)

The purpose to put an aux. power is to control the generator start delay time under the Power grid-Generator mode, if without aux. power, the generator start delay time is 0s, if the generator start delay function not needed, then no need to connect the aux. power .

401~404 fire linkage control terminals

401, 402-- Fire linkage control signal input, this terminal external only can connect to a set of NO passive contact (if the signal from fire-fighting equipment is an active signal, must first connect through a small relay, then connect the relay NO point to controller) when external contact closed ATS immediately transfer to OFF position and cutoff the power supply.

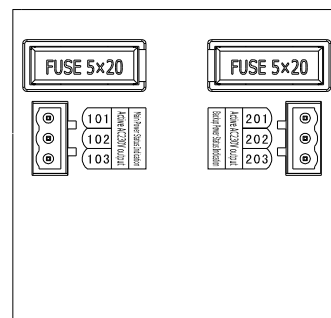

A Type Controller

403, 404—Inside is a set of NO relay contact point, used for sending the fire-fighting movement signal back; when it is normal, the contact is normal open status, when there is fire-fighting signal input to the controller, and the switch transfer to OFF position, the 403 and 404 closed. (Notes: when the fire linkage function is active, the ATS will stop working, if want the ATS to working again, must first clear up the fire-fighting signal and then press any button on the control panel, the ATS will recovery normal working)

501~503: Generator start control signal output

When the backup power is Auto start generator, users can connecting the 501~503 terminals to the generator controller to achieve the generator auto start function, inside 501~503 terminal, is a set of passive relay contact point, 502 is the relay common terminal, 503 is relay NC point, 501 is relay NO point; Under power grid - generator mode and auto transfer mode, when main power normal, 502 and 501 is closed, 502 and 503 open, if main power failure and backup power no power, 502 and 503 closed after generator start delay time, meanwhile 502 and 501 open to send generator start signal, after generator start successfully ATS auto transfer to backup power supply, if main power recovery good, then controller after recovery delay time to control the switch transfer to main power supply, after main power ON, 502 and 501 closed after generator stop delay time, 502 and 503 open to send generator stop signal.

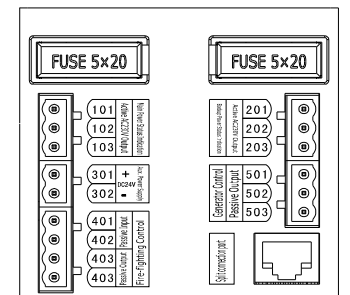

B/C/D Type Controller

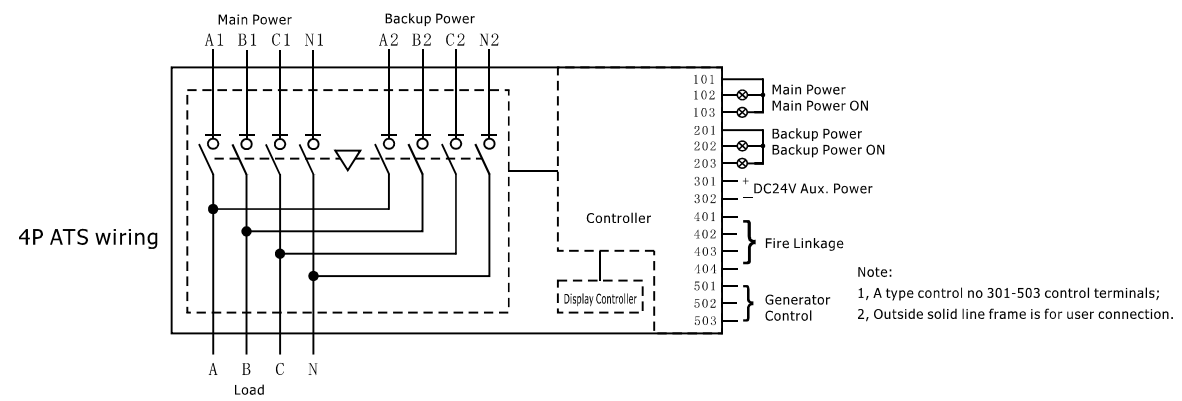
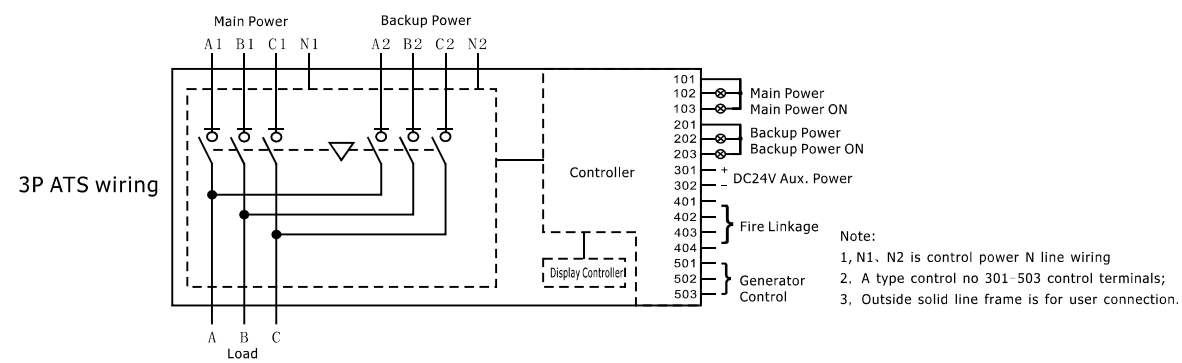

11. Common Faults and Solutions

Fault Status	Fault Causes	Solutions
Controller Indicator not lighting after Power ON	Input terminal bad contact	Ensure the input connection tighten and good contact
	Controller Fuse Failure	Put new fuse link
Controller Indicate phase missing	Phase line bad contact	Remove wiring fault
	Phase voltage lower than set under-voltage value	Power supply fault, transfer to the normal power
Controller Display Normal ATS not working	Controller under stop status	Pull the pull switch to the working position

12. Quality Assurance and After-sale Service